

SMiCON

performance. regardless.



www.smicon.com



SMICON was founded in 2003 to secure optimal Sales- and Supply Chain-Processes and Cultural Relevant Services, as well as providing a general consulting function in Sales, Project Management, Training and International Networking to the highest possible industry standards.

Operating out of the United Arab Emirates and the Kingdom of Saudi Arabia, SMICON is known for the “German” way of delivering high quality Services with focus on Global Sourcing, Business Development Management, and Key Supplier Management for Middle Eastern, Asian, and Eastern European Countries and well as Connecting “Key Players” across Sectors and Continents.

“MADE IN GERMANY, EXECUTED WORLDWIDE” ... this is, how SMICON can be best transcribed.

In 2009 SMICON acquired Germany-based istratex GmbH. istratex GmbH is a Defence- and Security-focussed Consulting Specialist with existing customers and partners in Defence, Law Enforcement and Commercial- / Governmental Security Agencies. With the Aquisition of istratex, SMICON was strenghtening its position as leading Consulting- and Project Management Specialist in the Middle East, focussing on the regions leading sectors: Engineering, Energy + Renewable Energy and Defence/Security.





HELMETS





BALLISTIC HELMET M97



The M97 is a PASGT-design helmet that has become a standard part of infantry equipment in many armies. The helmet can be produced with either three or six-point suspension/retention system, which provides space between the head and inner helmet surface, thus reducing the trauma from the blow. Also, this space enables ventilation.

BALLISTIC HELMET M97S

SIZE	HEAD SIZE (cm)	WEIGHT (g)	PROTECTION LEVEL NIJ STD 0106.01	V ₅₀ (m/s) STANAG 2920
Medium	54 - 58	≤1400g	IIIA	> 650
Large	58 - 62	≤1450g		

Product code: 31300099

BALLISTIC HELMET M97P

SIZE	HEAD SIZE (cm)	WEIGHT (g)	PROTECTION LEVEL NIJ STD 0106.01	V ₅₀ (m/s) STANAG 2920
Medium	54 - 58	≤1450g	II	> 600
Large	58 - 62	≤1550g		

Product code: 31300299

BALLISTIC HELMET M05



The M-05 is a MICH-design helmet that was originally made for Special Operations Forces. This helmet provides flexibility regarding communication capabilities, and offers improved field of vision, reduced weight and unobstructed hearing. Higher rear edge enables comfortable wearing of the helmet along with other parts of protective equipment.

BALLISTIC HELMET M05S

SIZE	HEAD SIZE (cm)	WEIGHT (g)	PROTECTION LEVEL NIJ STD 0106.01	V ₅₀ (m/s) STANAG 2920
Medium	54 - 58	≤1140g	IIIA	> 650
Large	58 - 62	≤1195g		

Product code: 31300499

BALLISTIC HELMET M05P

SIZE	HEAD SIZE (cm)	WEIGHT (g)	PROTECTION LEVEL NIJ STD 0106.01	V ₅₀ (m/s) STANAG 2920
Medium	54 - 58	≤1260g	II	> 600
Large	58 - 62	≤1330g		

Product code: 31300699

TABLE WITH BALLISTIC DATA

Ammunition	Ammunition Weight		Maximum Velocity		Energy (J)
	(g)	(Gr)	(m/s)	(ft/s)	
9mm PARA	8	124	441	1450	780
9mm NORMA 19022	7,5	116	410	1345	630
7,65mm Tokarev (steel jacketed)	5,5	85	450	1480	555
357 Magnum JSP	10,2	158	396	1300	800
44 Magnum SWC-GC	15,5	240	441	1450	1510

All helmet models can be protected with protective paint or with ABS layer





DEMINEING HELMET M97A



Demining helmet represents a composing part of protective equipment intended to protect experts for explosive devices against dangers that arise from possible detonations, such as all types of high velocity fragments, high pressure and intense heat. The helmet allows the use of microphone and telephone systems.

The helmet consists of a shell, suspension/retention system and a visor. The visor is made as laminated of acrylic and polycarbonate material, and is attached to the helmet. The visor is adjustable and it offers a clear and wide range of visibility.

Weight of helmet with visor: $\leq 2950\text{g}$ $V_{50} > 650\text{ m/s}$

Product code: 3 1 300899



DEMINEING VISOR
Product code: 3 1 301099

TABLE WITH BALLISTIC DATA FOR HELMET M97A

Ammunition	Ammunition Weight		Maximum Velocity		Energy (J)
	(g)	(Gr)	(m/s)	(ft/s)	
9mm PARA	8	124	441	1450	780
9mm NORMA 19022	7,5	116	410	1345	630
7,65mm Tokarev (steel jacketed)	5,5	85	450	1480	555
357 Magnum JSP	10,2	158	396	1300	800
44 Magnum SWC-GC	15,5	240	441	1450	1510





ANTI-RIOT HELMET



The anti-riot helmet provides full coverage of the user's head. It is designed to protect the head against mechanical impacts coming from rocks, bottles and other throwing objects, as well as against chemicals and liquids that are often used during riots.

Helmet shell is made of polycarbonate that is self-extinguishing and is resistant to organic and inorganic acids, water, oils, neutral and other salts.

The helmet consists of:

- Polycarbonate shell
- Styrofoam
- Suspension/retention system
- Polycarbonate visor
- Visor attaching elements
- Neck protector

In addition, the helmet has excellent mechanical characteristics in wide temperature range, from -30°C to $+50^{\circ}\text{C}$. The detachable neck protector is made of different types of foam embedded in fine leather. Base part of the adjustable suspension/retention system is made of quality leather and synthetic mesh. The visor is 3mm thick and features transparency of 85% and it is resistant to weather conditions.

Standard colors: black, white, blue

Product code: **31800099**

ANTI-RIOT HELMET WITH FLAT VISOR



The assembly of helmet with flat visor provides more space for using the protective mask, even when the visor is lowered in a protective position. Upon request, the visor may come with anti-fog and anti-scratch protection.

Standard colors: black, white, blue

Product code: **31800199**





BALLISTIC PLATES





PROTECTION LEVEL III



The ballistic plate of protection Level III provides protection against the types of ammunition listed in the table below, as well as protection against ammunition up to Level III as defined in NIJ standard 0101.04. In addition to the mentioned grains, the Level III plate provides protection against all types of common grain rifle ammunition, including 7,9 mm caliber. The external layer can be plastic or fabric. This plate, as all other SMICON MDP plates, is shaped to provide a comfortable fit on the front and back. The table below lists the ballistic protection factors of the plates with respect to various types of ammunition within defined velocities. Plates can be produced as single curve or multi curve.

Weight: $\leq 1450g$

Plate dimensions: 250mm x 300mm

Product code: 31301299

TABLE WITH BALLISTIC DATA

Bullet type	Maximum velocity (m/s)
7,62 Nato Ball 150 Grain M-80 FJM	853
7,62 Nato Ball 150 Grain M-80 (Steel Jacketed)	853
30,06 PSP 180 Grain	824
.30 Carabine 110 Grain FJM	595
12 Gauge Rifled Slug	473
7,62 x 39 Ball	732

THE OPTION OF ANTI-TRAUMA LAYER



The plates may come with additional layer made of foam that serves as anti-trauma layer. Foam is 10 mm thick.

Product code: 31301399





PROTECTION LEVEL III+ S-TYPE



Ballistic plates of Level III+ provide protection between Level III and Level IV as defined in NIJ STD 0101.04, particularly with respect to 5.56mm SS 109 caliber ammunition. SMICON MDP produces two versions of Level III+ plates (see other plate below). The external layer can be plastic or fabric. See the table below for protection factor within defined velocities.

Weight: $\leq 2150g$

Plate dimensions: 250mm x 300mm

Product code: **31301499**

PROTECTION LEVEL III+ E-TYPE



Bearing in mind the continual struggle to find lighter-weight solutions for soldiers' equipment, the Company „SMICON“ has introduced a significantly lighter version of the Level III+ plate, and that is E-type plate. For two plates of this type, the front and rear one, the weight savings is around 800g, or 3.4 lbs. See the table below for protection factor within defined velocities.

Weight: $\leq 1750g$

Plate dimensions: 250mm x 300mm

Product code: **31301599**

TABLE WITH BALLISTIC DATA

Bullet type	Maximum velocity (m/s)
5.56mm FMC 55 Bullet	938
5.56mm AP 4g SS109/M855 AP	942
7.62 Nato Ball 150 Grain M-80 FMJ	853
7.62 Nato Ball 150 Grain M-80 (steel jacketed)	853
.30 Carabine 110 Grain FMJ	595
12 Gauge Rifled Slug	473
7.62 x 39 Ball	732





PROTECTION LEVEL IV



Plates with protection level IV, the highest level produced, provide protection against armor-piercing bullets, providing maximum safety to soldiers. See the table below for protection factors within defined velocities according to NIJ Standard 0101.04. The external layer can be plastic or fabric. Plates can be produced as single-curve or multi-curve.

Alumina plate features:

- Available sizes: 300x250 mm (Weight: ≤ 3300 g), 350x250 mm, 350x270 mm, 150x150 mm.

Product code: **31301699**



Carbide plate features:

- Available sizes: 300x250 mm (Weight: ≤ 2600 g), 350x250 mm, 350x270 mm, 150x150 mm.

Product code: **31302099**



TABLE WITH BALLISTIC DATA

Bullet type	Bullet weight (g)	Maximum velocity (m/s)
7.62 x 63mm APM2	10.8	886
5.56mm - SS109/M855 AP (.223)	4	945
7.62 x 39mm PS Ball (AK 47)	7.97	732





BALLISTIC VESTS





The company "SMICON" MDP manufactures a wide spectrum of ballistics vests in order to satisfy different operational requirements which depend on users needs (army, police, security units, private use). MDP customers are given a wide range of choices when purchasing ballistic vests; from protection level and ballistic surface area to type of ballistic material and accessories, all of which have a bearing on price. All MDP vests are made using high-quality materials with a view towards striking the right balance between safety, comfort, weight and price.

Protection Levels

MDP ballistic vests are produced in number of different models and provide levels of protection according to NIJ Standard 0101.04

Protection levels above IIIA (levels III and IV) require insertion of hard ballistic plates. All the external vests (those worn over other garments) have pouches for the insertion of ballistic plates. The pouches may be accessed from the sides, or from above, as per customer request.

Fabrics for the shell of the vest

The fabrics for the shell of externally worn vests are made of either 100% durable polyamide with a polyurethane coating, or 100% polyester with a PVC coating. Both these fabrics are waterproof and water-repellent. The shell fabrics of concealed vests (worn close to the body) are made of a cotton-polyester mix that increases wearing comfort. Both the external and concealed vests comprise ballistic panels (ballistic fillings), where the fabric that encloses the ballistic material is made of 100% durable polyamide with a polyurethane coating, or 100% polyester with a PVC coating.

The OUTLAST Option

The company "SMICON" MDP, a licensed partner of OUTLAST®, offers customers the option of including OUTLAST® lining in any of its ballistic vests. Vests made with OUTLAST®, a thermo-regulating fabric originally designed for use in space, are more comfortable to wear as the material will absorb, store and release excess body heat. Therefore the user experiences less sweat and less chill, for temperature changes are balanced. OUTLAST® works at the molecular level to provide greater comfort in all weather conditions.

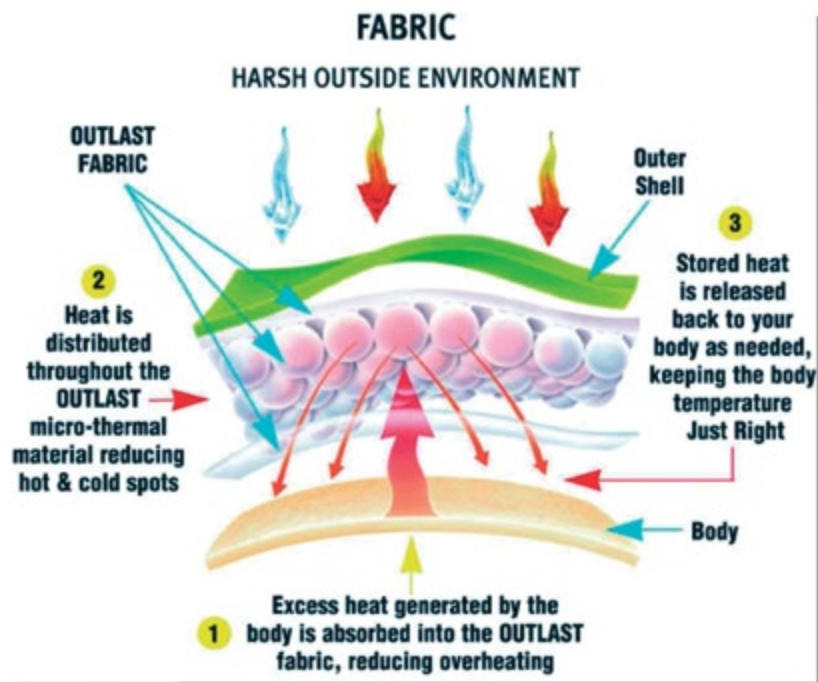

BALLISTIC VESTS

SMICON MDP



OPTIONAL BALLISTIC ACCESSORIES

Some vests come with fixed or detachable ballistic collars, groin protectors or shoulder protectors, while others have the option of combining these accessories per customer request. These accessories are shown on picture.



Collar guard: **A** Groin guard: **B** Shoulders guard: **C**

AREA OF PROTECTION ON BALLISTIC VESTS

(measures in m²)

NO.	PRODUCT	FILLING TYPES (XL size)			ADDITIONAL PROTECTION		
		Full	Compact	Comfort	Collar guard A	Groin guard B	Shoulders guard C
1.	Top univezal	0.467	-	-	0.062	0.124*	0.160
2.	M-MD vest	0.440	0.317	0.224	0.064	0.065	0.086
3.	Tactic	0.482	-	-	0.042	0.055	-
4.	Handy	0.619	-	-	0.039	0.064	-
5.	Paragon	0.566	0.317	0.224	0.025	0.199*	0.059
6.	Triband	0.364	0.317	0.224	0.032	0.049	-
7.	Sentry	0.408	0.317	0.224	0.032	0.049	-
8.	Seven	0.505	0.317	0.224	-	-	-
9.	Demining	0.236	-	-	0.060	0.089	0.060
10.	Marine	-	0.317	-	0.064	-	0.038
11.	Manager	-	0.317	0.224	-	-	-
12.	Diplomat	0.462	0.317	0.224	-	-	-
13.	Escort	0.408	0.317	0.224	-	-	-
14.	VIP	0.322	-	-	-	-	-
15.	Quick	-	0.317	0.224	0.064	0.065	-
16.	ATV vest	-	0.317	0.224	-	-	0.086

Remark:

* Protection area refers to front and rear protectors

There is no ballistic protection on the back side of demining vest

Possible surface variations: $\pm 0.02 \text{ m}^2$

TABLE OF MEASURES

(measures in cm)

NO.	BODY MEASURES	S	M	L	XL	XXL
		38/40	42/44	46/48	50/52	54/56
1.	Body height	164 - 167	168 - 171	172 - 175	176 - 179	180 - 183
2.	Chest girth	84 - 88	88 - 93	93 - 100	100 - 108	108 - 116

Remark:

Values in table refer to body measures, not to measures of the vest.

NIJ STANDARD - 0115.00 STAB RESISTANCE OF PERSONAL BODY ARMOR

Protection Level	E1 Strike Energy (J)	Max. penetration at E1 (mm)	E2 Overtest Strike Energy (J)	Max. Penetration at E2 (mm)
1	24	7	36	20
2	33	7	50	20
3	43	7	65	20

Applicable to Edge Blade and Spike Test

Dual Mass System

Composite Backing





TOP UNIVERSAL VEST



This vest is intended for personnel exposed to high risks due to field work. It provides maximum body protection which comprises basic protection of the chest, back and side area along with optional protection of the shoulders, groins and neck. Additional protection of the chest, back and sides is provided by inserting ballistic plates into suitable pockets. Additional comfort and air circulation is achieved by incorporating XD spacer fabric. Webbing straps on full outer vest area for attaching any pouch configurations.

Levels of ballistic protection according to NIJ standard 0101.04
IIIA, (as well as III, III+ and IV with plates)

Optional: Stab resistance according to NIJ STD 0115.00 (table on page 13)

Optional ballistic accessories:

Additional protection: A, B and C

Filling options: full

Colors: various colors available as per customer request

Sizes: M, L, XL, XXL

Product code: **31302699**





M-MD VEST



This vest is intended for the special units. It provides maximum comfort and mobility. The vest has integrated hydration system on the back. Webbing straps on full outer vest area for attaching any pouch configurations. The vest has pockets for inserting the ballistic plates.

Level of ballistic protection according to NIJ standard 0101.04
IIA, II, IIIA (as well as III, III+ and IV with plates)

Optional: Stab resistance according to NIJ STD 0115.00 (table on page 13)

Optional ballistic accessories:

Additional protection: A, B and C

Filling options: full, compact or comfort

Colors: various colors available per customer request

Sizes: M, L, XL, XXL

Product code: **31303099**





TACTIC VEST



The vest includes two internal pockets on the front and rear side for insertion of ballistic plates. Webbing straps on full outer vest area for attaching various holsters.

Level of ballistic protection according to NIJ standard 0101.04
IIA, II, IIIA, (as well as III, III+ and IV with plates)

Optional: Stab resistance according to NIJ STD 0115.00 (table on page 13)

Optional ballistic accessories:

Additional protection: A and B

Filling options: full

Colors: various colors available per customer request

Sizes: M, L, XL, XXL

Product code: **31303499**





HANDY VEST



This vest is favored by special police units as it offers various options for placing fixed and detachable pouches for the ammunition and other equipment. Also, the vest has pockets for inserting the ballistic plates.

Level of ballistic protection according to NIJ standard 0101.04
IIA, II, IIIA, (as well as III, III+ and IV with plates)

Optional: Stab resistance according to NIJ STD 0115.00 (table on page 13)

Optional ballistic accessories:

Additional protection: A and B

Filling options: full

Colors: various colors available per customer request

Sizes: M, L, XL, XXL

Product code: **31303899**





PARAGON VEST



PARAGON vest is intended for military units and it has maximum area of protection. The vest includes front and back pouches for inserting the ballistic plates (side access on shown vest), collar, shoulders and groin protectors. The vest has a three-point Velcro attachment system: two side flaps and a flap over the left shoulder.

Level of ballistic protection according to NIJ standard 0101.04
IIA, II, IIIA (as well as III, III+ and IV with plates)

Optional: Stab resistance according to NIJ STD 0115.00 (table on page 13)

Optional ballistic accessories:

Additional protection: A, B and C

Filling options: full, compact or comfort

Colors: various colors available per customer request

Sizes: M, L, XL, XXL

Product code: **31304299**





TRIBAND VEST



The TRIBAND model is designed for external wearing. The vest has a three-point Velcro attachment system that enables quick and easy doffing: two points on the sides and one on the left shoulder. The vest has two external pouches for insertion of ballistic plates.

Level of ballistic protection according to NIJ standard 0101.04
IIA, II, IIIA (as well as III, III+ and IV with plates)

Optional: Stab resistance according to NIJ STD 0115.00 (table on page 13)

Optional ballistic accessories:

Additional protection: A and B

Filling options: full, compact or comfort

Colors: black, dark blue

Sizes: M, L, XL, XXL

Product code: **31304699**





SENTRY VEST



The SENTRY vest is designed for external wearing and includes two pouches for inserting the ballistic plates. This vest also has a three-point Velcro attachment system but it differs from the TRIBAND model in a way that it is fastened on the sides by means of flaps with Velcro instead of elastic bands with Velcro.

Level of stab resistance according to NIJ standard 0101.04
IIA, II, IIIA, (as well as III, III+ and IV with plates)

Optional: Stab resistance according to NIJ STD 0115.00 (table on page 13)

Optional ballistic accessories:

Additional protection: A and B

Filling options: full, compact or comfort

Colors: black, dark blue

Sizes: M, L, XL, XXL

Product code: **31305099**





SEVEN VEST



Ergonomic solution of this model provides comfort and flexibility during all field activities. The vest provides maximum protection with a minimum weight. Four point Velcro attachment system. Pouches for inserting ballistic plates.

Level of stab resistance according to NIJ standard 0101.04
IIA, II, IIIA, (as well as III, III+ and IV with plates)

Optional: Stab resistance according to NIJ STD 0115.00 (table on page 13)

Optional ballistic accessories:

Filling options: full, compact or comfort

Colors: black, dark blue

Sizes: M, L, XL, XXL

Product code: 31305499





DEMINING VEST



Demining vest protects experts for explosive devices against dangers that arise from possible detonations, such as all types of high velocity fragments ($V_{50} > 500\text{m/s}$), high pressure and intense heat. Back side is made of mesh fabric, for better ventilation and comfort.

Protected areas: front side, neck, groins and shoulders.

Level of protection is provided according to customer demands.

Standard ballistic protection level of DEMINING VEST is IIIA, but it can be upgraded by inserting the ballistic plate (on the front) for levels III or IV, per NIJ STD 0101.04

Filling options: full

Product code: 31305899





MARINE VEST



This ballistic life saving vest is intended for crews of the ships, boats and other vessels. It features full area of protection. It has four points adjustment system by means of Velcro tapes and plastic sliders. Side pockets for inserting ballistic plates. Webbing belt with double retention buckle for additional waist size adjustment. Two piece collar with ballistic filling. Additional collar padded with foam and marked with 3M reflective tape. Front and back pouches for inserting the ballistic plates. Heavy duty drag handle on the back. Webbing tapes with plastic buckles for securing the vest among the legs. Two pockets on the front left side, for whistle and compass.

Level of ballistic protection according to NIJ standard 0101.04
IIA, II, IIIA (as well as III, III+ or IV with plates).

Optional ballistic accessories
Additional protection: A and C
Filling options: full
Colors: various colors available per customer request
Sizes: M, L, XL, XXL

Product code: 31306299





MANAGER VEST



The MANAGER model is intended for use as a formal vest under a suit or other jacket. Seemingly, it looks no different from a fashionable button-vest with two small pockets. The external fabric is a mix of wool and synthetic material. The vest is fastened in two points by means of Velcro system.

Level of ballistic protection according to NIJ standard 0101.04
IIA, II, IIIA

Optional: Stab resistance according to NIJ STD 0115.00 (table on page 13)

Optional ballistic accessories
Filling options: compact or comfort
Colors: black, grey, dark blue
Sizes: M, L, XL, XXL

Product code: **31306699**





DIPLOMAT VEST



The vest is designed for concealed wearing with a view towards increasing the level of comfort while still providing solid protection. The external fabric is a cotton-polyester mix and the vest is fastened at four points by means of Velcro system. Elastic bands at the waist area provide the vest to fit tightly, hidden under the clothing.

Level of ballistic protection according to NIJ standard 0101.04
IIA, II, IIIA

Optional: Stab resistance according to NIJ STD 0115.00 (table on page 13)

Optional ballistic accessories

Filling options: full, compact or comfort

Colors: black, gray, white

Sizes: M, L, XL, XXL

Product code: **31307099**





ESCORT VEST



The ESCORT vest is designed to be worn as a concealed vest, but it may also be worn externally. The exterior fabric is a cotton-polyester mix that is comfortable to the user. The vest has a three-point Velcro attachment system.

Level of ballistic protection according to NIJ standard 0101.04
IIA, II, IIIA, (as well as III, III+ and IV with plates).

Optional: Stab resistance according to NIJ STD 0115.00 (table on page 13)

Optional Ballistic Accessories

Filling options: full, compact or comfort

Colors: black, dark blue

Sizes: M, L, XL, XXL

Product code: **31307499**





VIP VEST



The VIP vest provides concealed protection while allowing maximum freedom of movement. The vest has four-point Velcro attachment system and elastic bands at the waist area.

Level of ballistic protection according to NIJ standard 0101.04
IIA, II, IIIA

Optional: Stab resistance according to NIJ STD 0115.00 (table on page 13)

Filling options: full
Colors: black, gray, white
Sizes: M, L, XL, XXL

Product code: **31307899**





QUICK VEST



The vest features quick release system. Four points Velcro adjustment system (two on the shoulders and two on the waist). Full outer vest area usage for MOLLE system. Separate MOLLE system on the shoulder back side for attaching the holster for communication device. Heavy duty drag handle on the back. Front and back pouches for inserting the ballistic plates. Upon request groin protector can be added.

Level of ballistic protection according to NIJ standard 0101.04
IIA, II, IIIA (as well as III, III+ and IV with plates)

Optional: Stab resistance according to NIJ STD 0115.00 (table on page 13)

Optional ballistic accessories:

Additional protection: A and B

Filling options: compact or comfort

Colors: various colors available per customer request.

Sizes: M, L, XL, XXL

Product code: **31308299**





ATV VEST



It is made of synthetic material with protective coating. Synthetic mesh lining for better ventilation. The vest has four points Velcro attachment system: two on the shoulders and two on the sides. Front and back pouches for inserting the ballistic plates. Full outer vest area usage for MOLLE system. On the shoulder part there is a separate MOLLE system for attaching the holster for communication device. Two webbing tapes with Velcro on the chest part are for hoses of hydration system (Camel bag). Heavy duty drag handle on the back.

Level of ballistic protection according to NIJ standard 0101.04
IIA, II, IIIA (as well as III, III+ and IV with plates)

Optional: Stab resistance according to NIJ STD 0115.00 (table on page 13)

Optional ballistic accessories:

Additional protection: C

Filling options: compact or comfort

Colors: various colors available per customer request

Sizes: M, L, XL, XXL

Product code: **31308699**







DEMINING ARMOR





DEMINEING SUIT MD-06



DEMINEING SUIT MD-06 is made to protect the user working in minefields or with explosive devices against dangers that arise from possible detonations, such as high velocity fragments, high pressure and intense heat. DEMINEING SUIT MD-06 consists of following parts:

- Protective hoses and sleeves
- Protective vest
- Belt with shoulder straps
- Helmet with visor M-97A
- Transportation bag

Total weight of demining suit for standard performance is 21 kg. Various colors and design are available. The front and back of the vest have pockets for inserting hard ballistic plates in order to increase protection level up to level III or IV (NIJ STD 0101.04.) There are four smaller pockets on the front of the vest for placing necessary equipment.

In addition, the DEMINEING SUIT MD-06 can be equipped with cooling system.

Available sizes: L, XL,XXL

Product code: 31308999



DEMINEING SUIT M-06 provides following levels of protection

No.	COMPONENTS	STANDARDS	
		NIJ 0101.04	STANAG 2920 V ₅₀
1.	Protective vest (front side)	IIIA	> 500 m/s
2.	Groin protector (front side)	IIIA	> 500 m/s
3.	Collar protection (front side)	IIIA	> 500 m/s
4.	Protective hose (front side)	IIA	> 400 m/s
5.	Protective sleeves (front side)	IIA	> 400 m/s

The visor provides protection from bullets 9mmPARA (FMJ 8.0g, Vmax=441 m/s).

Protection level of DEMINEING SUIT can be upgraded by inserting ballistic plate (front) of the following protection levels: level III or level IV per NIJ STD 0101.04.





DEMINEING SUIT MD-06FB



DEMINEING SUIT MD-06FB produced by the Company "MILE DRAGIC PRODUCTION" is intended for experts for explosive devices. Demining suit provides protection of the front side of the body against dangers that arise from possible detonations, such as all types of high velocity fragments ($V_{50} > 500 \text{ m/s}$), high pressure and intense heat. The suit enables substantial mobility during field work. Back side of the suit is made of mesh fabric for better air circulation. Cover of the suit is made of materials of various colors and can be made to provide protection in visible and near IR part of EM spectrum. There are pockets on the front side for placing the necessary equipment. Total weight of complete DEMINEING SUIT M-06FB is 11 kg.

DEMINEING SUIT M-06FB also includes:

- Helmet M-97A with visor
- Belt set
- Carrying bag



Product code: 31309199

DEMINEING SUIT M-06FB provides following levels of protection

No.	COMPONENTS	STANDARDS	
		NIJ 0101.04	STANAG 2920 V_{50}
1.	Protective vest (front side)	IIIA	> 500 m/s
2.	Groin protector (front side)	IIIA	> 500 m/s
3.	Collar protection (front side)	IIIA	> 500 m/s
4.	Protective hose (front side)	IIA	> 400 m/s
5.	Protective sleeves (front side)	IIA	> 400 m/s

The visor provides protection from bullets 9mm PARA (FMJ 8.0g, $V_{max} = 441 \text{ m/s}$).

Protection level of DEMINEING SUIT can be upgraded by inserting ballistic plate (front) of the following protection levels: level III or level IV per NIJ STD 0101.04.





DEMINEING VEST



Demining helmet with visor is used to protect experts for explosive devices against high velocity fragments. The helmet offers protection against bullets and fragments of explosive ammunition, bombs and extreme heat. The helmet shell is made of composite materials by unique technology. The shape of the helmet protects ears and allows the use of microphone and radio-telephone systems. The helmet consists of a shell, suspension/retention system and a visor.

The weight of helmet with visor is $\leq 2950\text{g}$ and their ballistic performance is $V_{50} > 650\text{m/s}$. When using a fragmentation simulator 5.56 mm, with the fragment weight of $1.1 \pm 0.02\text{ g}$, the helmet shell offers a ballistic protection level of $V_{50} > 1000\text{m/s}$ according to STANAG 2920. The visor is made as laminated of acrylic and polycarbonate material and is attached to the helmet. The visor protects the face against fragments and projectiles of high velocities and has following ballistic performance: when using bullets 9 mm PARA (FMJ 8.0 g), V_{max} is 441 m/s). It is adjustable and offers a clear and wide field of vision. Weight of the visor is 1040g. Because of the extraordinary characteristics, high ballistic protection level, optimal weight, security and comfort, helmet with visor became a part of standard equipment for military and police bomb squads.

The series of investigations were conducted according to: STANAG 2920, NIJ STD and MIL STD 662 standards. The accuracy and efficiency are guaranteed by the team of experts. All metal parts are protected against corrosion.

Product code: **31300899**

TABLE WITH BALLISTIC DATA FOR HELMET M97A

Ammunition	Ammunition Weight		Maximum Velocity		Energy (J)
	(g)	(Gr)	(m/s)	(ft/s)	
9mm PARA	8	124	441	1450	780
9mm NORMA 19022	7,5	116	410	1345	630
7,65mm Tokarev (steel jacketed)	5,5	85	450	1480	555
357 Magnum JSP	10,2	158	396	1300	800
44 Magnum SWC-GC	15,5	240	441	1450	1510





DEMINING VEST



Demining vest protects experts for explosive devices against dangers that arise from possible detonations, such as all types of high velocity fragments ($V_{50} > 500\text{m/s}$), high pressure and intense heat. Back side is made of mesh fabric, for better ventilation and comfort.

Protected areas: front side, neck, groins and shoulders.

Level of protection is provided according to customer demands.

Standard ballistic protection level of DE-MINING VEST is IIIA, but it can be upgraded by insertion of ballistic plate (on the front) for levels III or IV, per NIJ STD 0101.04.

Filling options: full

Product code: 31305899





DEMINING BOOTS MD-03



They represent a part of protective equipment used during movement through the minefield, and they are effective against antipersonnel mines (equivalent to 75g TNT). The upper part of the DEMINING BOOTS (apart from the sole) is identical to military boots. It is made of finest quality leather and is glued and stitched to the sole.

The upper part of the sole comprises a ballistic plate which minimizes the direct effect of detonations against the user's feet. The middle sole is constructed of a microporous material that is 30 mm thick and its purpose is to absorb the impact of detonations. The lower part of the sole is a standard military boots sole.

The boots are produced according to the French measurement system and come in sizes 41 to 46.

Weight of one pair of DEMINING Boots, size 42, is less than 3.2 kg.

Demining boots are tested with static and dynamic methods.

Product code: 31310099





BALLISTIC SHIELDS





HAND BLOCK



Ballistic shield is intended for Special units. It is designated to protect the body against direct impact and ricochet of the pistol grain conclusive with caliber 44 Magnum.

Inner side of the shield is equipped with handle. It is produced in two variants: with/without ballistic window - visor.

Dimensions:
- 800mm x 500mm

Product code: **31800299**



TECHNICAL CHARACTERISTICS

Shield protection level as per the NIJ STD 0101.04	IIIA
Visor protection level as per the NIJ STD 0101.04	IIIA
Visor opening	400 x 100 mm
Ballistic part mass (maximum)	< 10 kg
Light for lighting the area (diode)	2 pieces
Dimensions	800 x 500 mm
Color	black





HAND BLOCK



Ballistic shield is intended for special units. It protects the user against rifle ammunition - regular grain conclusive with caliber 7.9mm.

There is a handle on the inner side of the shield. We produce two types of ballistic shields: with or without the ballistic glass - visor.

Dimensions:

- 850mm x 500mm

Product code: **31800099**

- 800mm x 400mm

Product code: **31800199**



TECHNICAL CHARACTERISTICS

Shield protection level as per the NIJ STD 0101.04	III
Visor protection level as per the NIJ STD 0101.04	III
Visor opening	200 x 100 mm
Ballistic part mass (maximum)	19 kg/m ²
Dimensions	850 x 500 mm 800 x 400 mm
Color	black





MEDIUM BLOCK



Ballistic shield is intended for special units. It protects the user against rifle ammunition - regular grain conclusive with caliber 7.9mm.

There is a handle on the inner side of the shield. We produce two types of ballistic shields: with or without the ballistic glass - visor.

Dimensions:

- 1200mm x 650mm

Product code: **31800399**



TECHNICAL CHARACTERISTICS

Shield protection level as per the NIJ STD 0101.04	III
Visor protection level as per the NIJ STD 0101.04	III
Visor opening	200 x 100 mm
Ballistic part mass (maximum)	19 kg/m ²
Dimensions	1200 x 650 mm
Color	black





BIG BLOCK



Ballistic shield is intended for special units. It protects the user against rifle ammunition - regular grain conclusive with caliber 7.9mm.

There is a handle on the inner side of the shield. We produce two types of ballistic shields: with or without the ballistic glass - visor.

Big block shield can be disassembled thus enabling the upper plate to be used independently as Hand block.

Dimensions:

- 1600mm x 850mm

Product code: 31800499



TECHNICAL CHARACTERISTICS

Shield protection level as per the NIJ STD 0101.04	III
Visor protection level as per the NIJ STD 0101.04	III
Visor opening	200 x 100 mm
Ballistic part mass (maximum)	19 kg/m ²
Dimensions	1600 x 850 mm
Color	black





BALLISTIC BLANKET



Ballistic blanket is made of high quality materials. Its purpose is wide, but it is mainly designed for VIP or individual protection. It can be used in critical situations, for example it can be held in front of windows, doors or vehicles in order to protect against explosive, bullets etc.

The ballistic material of the protective blankets is self-extinguishing and it is resistant against ammunition and fragments of high velocity, with $V_{50} > 500\text{m/s}$ as per STANAG 2920. Ballistic blanket is packed in separate bag. Bag is made of waterproof, high strength material.

Dimensions and weight:

- 900mm x 1800mm - 10kg
- 1200mm x 1200mm - 9kg
- 1200mm x 1600mm - 12kg

Product code: **31800599**



TRANSPORT BAG

LEVEL OF PROTECTION IIIA ACCORDING TO NIJ 0101.04 STANDARD

CLASS	NIJ STD 0101.04	Bullet Type	Max. velocity	
			Fps	mps
IIIA	Protect against all Class I, Class IIA, Class II as well as all ammunition listed. Meets and exceeds NIJ STD 0101.04 for Type IIIA Armor including Back face Deformation (Blunt Trauma)	44 magnum 240 Bullet (15,5g) SJHP	1450	441
		9mm 124 Bullet (8,0g) FMJRN	1450	441





BALLISTIC CASE



It provides protection to the user against regular pistol and revolver ammunition inclusive with calibers 9mm Para, .357 Magnum and .44 Magnum. Level of protection without protective ballistic plate is $V_{50} > 500\text{m/s}$.

Ballistic case (unfolded) is available in two dimensions:

- 600mm x 1600mm and
- 600mm x 1200mm

By folding it - the form of case is obtained.

Weight: 5.5 kg/m²

Product code: 31800899



LEVEL OF PROTECTION IIIA ACCORDING TO NIJ 0101.04 STANDARD

CLASS	NIJ STD 0101.04	Bullet Type	Max. velocity	
			Fps	mps
IIIA	Protect against all Class I, Class IIA, Class II as well as all ammunition listed. Meets and exceeds NIJ STD 0101.04 for Type IIIA Armor including Back face Deformation (Blunt Trauma)	44 magnum 240 Bullet (15,5g) SJHP	1450	441
		9mm 124 Bullet (8,0g) FMJRN	1450	441







ANTI-RIOT EQUIPMENT





ANTI-RIOT VEST



Product code: 31801099

These vests are intended for special police forces and anti-riot squads.

The vests protect the upper body and the arms from blows with batons, stones etc. and from stabs with sharp objects. The vests are flexible and provide excellent mobility.

There are two models of anti-riot vest, with the same protective features.

- The first model of the vest is made of flexible foam material covered with synthetic fabric, with added inner protective elements made of plastics.
- The second model is made of flexible spacer material, with added outer protective plastic elements.

The basic assembly of both models consists of front and back body-shaped parts with shoulder protection which are joined together by means of Velcro system. The weight of the basic assembly is approximately 2.1 kg.

Also, there are following optional elements that can be added to the basic assembly of the vests:

- Groin protectors
- Forearm protectors
- Various pouches and holsters



Product code: 31801199





ANTI-RIOT HELMET



The anti-riot helmet provides full coverage of the user's head. It is designed to protect the head against mechanical impacts coming from rocks, bottles and other throwing objects, as well as against chemicals and liquids that are often used during riots.

Helmet shell is made of polycarbonate that is self-extinguishing and is resistant to organic and inorganic acids, water, oils, neutral and other salts.

The helmet consists of:

- Polycarbonate shell
- Styrofoam
- Suspension/retention system
- Polycarbonate visor
- Visor attaching elements
- Neck protector

In addition, the helmet has excellent mechanical characteristics in wide temperature range, from -30°C to +50°C. The detachable neck protector is made of different types of foam embedded in fine leather. Base part of the adjustable suspension/retention system is made of quality leather and synthetic mesh. The visor is 3mm thick and features transparency of 85% and it is resistant to weather conditions.

Standard colors: black, white, blue

Product code: **31800099**

ANTI-RIOT HELMET WITH FLAT VISOR



The assembly of helmet with flat visor provides more space for using the protective mask, even when the visor is lowered in a protective position. Upon request, the visor may come with anti-fog and anti-scratch protection.

Standard colors: black, white, blue

Product code: **31800199**





ANTI-RIOT SHIELD

Anti-riot shield is intended for special police forces and anti-riot squads. It is designed to protect against shotgun ammunition, mechanical blows, fragments blows, chemicals and other liquids. On the inner side of the shield there is a built-in shock absorber which provides reduction in mechanical impact. It is anatomically shaped to provide better comfort to the user. The handle is made of aluminium coated with polyurethane. A baton carrier is also fixed on the inner side of the shield.

The materials used in producing our shields provide:

GOOD MECHANICAL CHARACTERISTICS

GOOD OPTICAL CHARACTERISTICS

GOOD THERMO-PHYSICAL CHARACTERISTICS



Product code: **31801499**



Product code: **31801599**

There are several models of shields depending on its thickness and dimensions:

Thickness of 4mm
Dimensions: 950mm x 580mm x 4mm
Weight 4,0kg

Thickness of 6mm
Dimensions: 1000mm x 580mm x 6mm
Weight 5,5kg

Thickness of 6mm
Dimensions: 1600mm x 600mm x 6mm
Weight 9,5kg





ANTI-RIOT PROTECTORS



LEGS PROTECTORS
Product code: **31801699**



ARM PROTECTORS
Product code: **31801799**

The harness is produced from spacer material with external plastic layer. Arms and legs protectors are anatomically shaped to provide undisturbed movement. There are built-in shock absorbers on the inside of protectors.

RUBBER BATON



RUBBER BATON MD-94
Product code: **31801899**

This Baton is produced of natural and synthetic rubber with a "hidden" metal stick in the middle which provides structural strength and makes it effective in action. The baton holder has anatomic shape which makes it easier to handle.

- Rubber baton MD-94
- Standard length 550mm
 - Handle diameter 30mm
 - Metal bar diameter 7mm
 - Rubber hardness Sh70
 - Total weight 630g



RUBBER BATON TONFA
Product code: **31801999**

- Rubber baton " TONFA "
- Standard length 650mm
 - Handle diameter 30mm
 - Metal bar diameter 7mm
 - Rubber hardness Sh80
 - Total weight 750g







PROTECTIVE SUITS





NBC SUIT



In order to satisfy high demand for protection against different types of weapons for mass destruction, including chemical warfare agents, the Company "SMICON" has produced the NBC SUIT 600200. Applying scientific innovations, technical experience and knowledge we have produced a suit that offers necessary protection against liquids, vapors, and aerosols carrying all types of chemical warfare agents, and still providing comfort to the user.

The NBC suit OFZ M 2000 is intended for multiple uses by personnel working under conditions of chemical warfare vapors and gases. In addition, it offers single use protection against chemical warfare drops, thermal impulse of nuclear exposure, or drops of napalm chemicals.

The suit consists of: Jacket with hood, trousers and transportation bag. Total weight is 3.0 kg.

The suit is made of a two-layered material, where the outer layer is a mixture of cotton and synthetic, treated to be hydrophobic and oil-repellent. The suit is made in all kinds of camouflage patterns providing high camouflage characteristics in visual and IR part of the EM spectrum. The inner layer is made of a special filter material (Saratoga), the top quality fabric of this type in the world.

Product code: **31000799**





RAIN PROTECTIVE SUIT



RAIN PROTECTIVE SUITS made by "SMICON" are certified for using in bad weather conditions, offering protection from rain, wind and cold. We produce comfortable and high quality rain suits using special materials. Our suits are produced of multilayer fabric made by **Sympatex®**. Middle layer is a non-porous membrane that is laminated between the outer waterproof fabric and the internal lining. **Sympatex®** membrane is 100% waterproof, 100% windproof and highly breathable. The perspiration in the form of vapor is easily transported away from the inside towards the outside. All seams are sealed thus additionally securing the suits from water penetration. The suits are made to be comfortable for wearing over standard military uniform. Currently we offer a Jacket with Hood, and Trousers. The Rain suits are made in all standard sizes with a weight of approximately 1.2 kg.

Product code: **31001399**

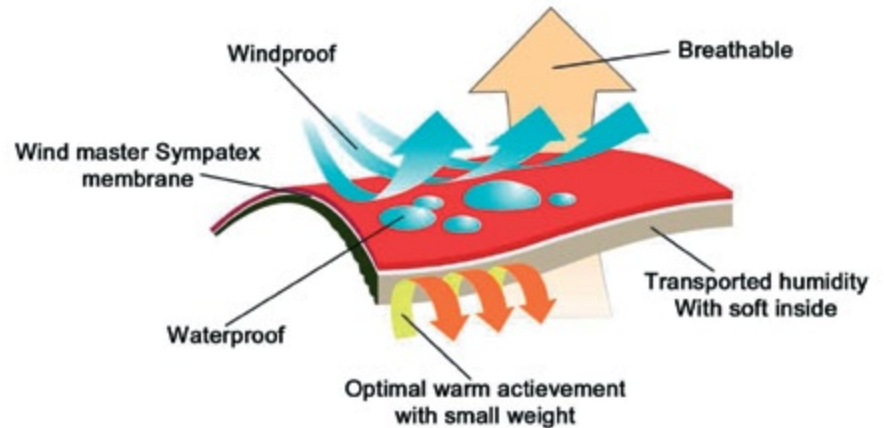

100% windproof



100% waterproof



highly breathable

SYMPATEX®
technology





FIREMAN OUTFIT FD-9



MD-Firefighter suit is produced of high-technology **NOMEX®** materials. The set is intended for maximum protection of firefighters during interventions, when they are exposed to high temperatures and flames. The protection is provided by the suit construction. The firefighter suit has a thermo-insulating lining, a moisture barrier to prevent water penetration and a breathable membrane. Clothes made of **NOMEX®** fabrics produced by **DuPont™** withstand high temperatures (non-combustible during short exposure to flame) and they are comfortable, durable and easy to maintain. The accessories built in these products are made by reputable producers such as **3M®**, **YKK®** and others. This type of clothes is ergonomically adjusted to its assignment. Its quality is confirmed by Accredited EU Laboratory STFI, according to EN 469.

NOMEX® materials are widely used for making protective clothes for firefighters, car racers, aircraft crews and other people that work in dangerous environment.

FD-9 Jacket is long, cut in the chest area and has no stitches in the shoulder part. This model has a high collar and a special zipper for fast and easy unbuttoning. There is a pocket for communication device on the front right side of the jacket and two pockets with flaps in the waist line. The sleeves are ended with the cuffs and ribbons that enable hooking them up to the fingers. The back of the jacket has Velcro tapes for attaching reflective signs.

FD-9 Trousers have an elastic tape for waist adjustment and suspenders with plastic buckles. There are two side pockets with flaps and Velcro. The trousers are reinforced on the knees with additional layer of **NOMEX®** material.

MD Firefighting suits FD-9 complies with EU directives and standards:

89/686/EEC – Appendix II

EN 469:2005+AC: 2006 (level of performance X2, Y2 and Z2)



NOMEX®



Product code: 31001899





FIREFIGHTER SET FD-10



FD-10 jacket is of a short style with high collar and raglan sleeves. This jacket enables greater mobility to the user. The jacket is buttoned with special zipper that enables fast and easy unbuttoning. In the chest area there is a pocket with the flap for keeping the communication device and a ring for hanging the gas detector, flash-light, gloves etc. There are two pockets with flaps in the waist area. On the sleeve, in the wrist area, there is a **NOMEX®** knitting of suitable length, with a side slot for pulling the thumb through, for wrist protection. In the elbow area there is reinforcement of special kind of self-extinguishing and non-slippery material.

FD-10 Trousers are of a flat style with higher belt on the back area, and with specially designed suspenders whose length may be adjusted by means of plastic buckles, synthetic and elastic tapes. In the shoulder area suspenders are padded with foam for better comfort. Buttoning is with zipper and snap-button, and on the side of the waist area there is an elastic tape for waist adjustment. On the sides of hoses there are pockets with flaps, as well as zippers for hose opening adjustment. The bottom back part of hoses is constructed in a way to prevent stepping on it. In the knee area and on the inside of the bottom of the hoses there are reinforcements made of special kind of self-extinguishing and non-slippery material.

Firefighting working suits FD-10 comply with EU directives and standards:
89/686/EEC – Appendix II
EN 469:2005+AC: 2006 (level of performance X2, Y2 and Z2)

Product code: **31002399**



NOMEX®





FIREFIGHTER WORKING SUIT FDW-9



Firefighter suit **FDW-9** is made of high-technology **NOMEX®** fabric, and it protects from short lived exposure to open flame. It is intended for the users that participate in fighting forest fires. The suit is designed according to its purpose, it is comfortable and easy to maintain. The suits are marked with incombustible yellow and grey reflective tapes for easier spotting the user when visibility is reduced.

FDW-9 Blouse is of a long style, buttoned with special zipper for fast donning and doffing. It also has additional buttoning with protective flap and incombustible Velcro tape. Raised collar with flap provides protection for the neck area. There are two pockets with zippers at the chest height and two pockets with flaps in the waist area.

FDW-9 Trousers are with the waist that is closed with button. There on the waist are sliders for the belt as well as larger sliders for the girdle. There are two sidelong pockets in the waist area. There are reinforcements in the form of additional layer of fabric on the knees and on the buttocks area. Hose openings may be adjusted by means of filet and Velcro tape.

Firefighting working suit **FDW-9** is made of **NOMEX®** fabric with a weight of 210g/m² and complies with EU directives and standards:
89/686/EEC – Appendix II
EN 340;
EN 15614:2007, A1+A2
EN 531:1995+A1:1998 (code A, code B1, code C1).

Product code: **31015699**



NOMEX®



PROTECTIVE SUITS

SMICON MDP

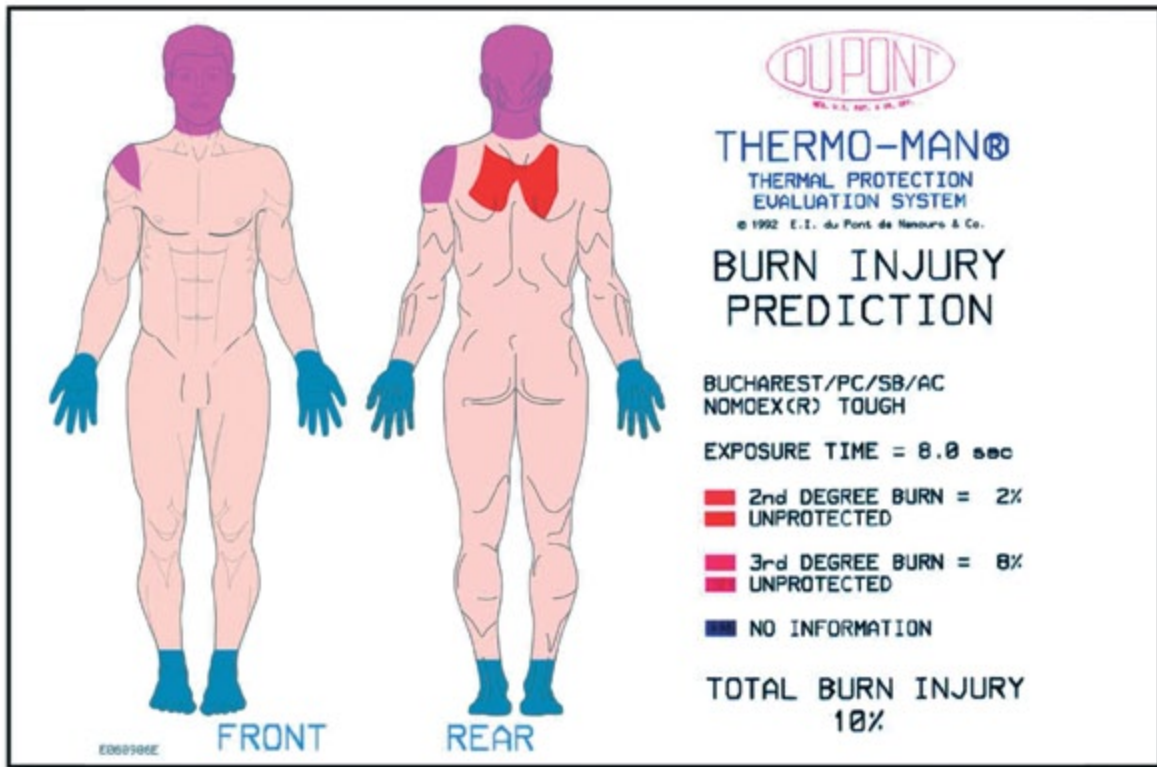

Burn injury prediction (head is not protected)

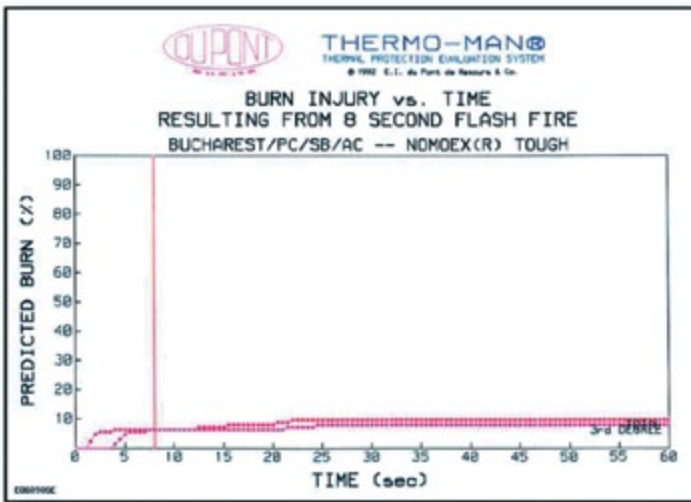

Burn injury vs. time resulting from 8 second flash fire

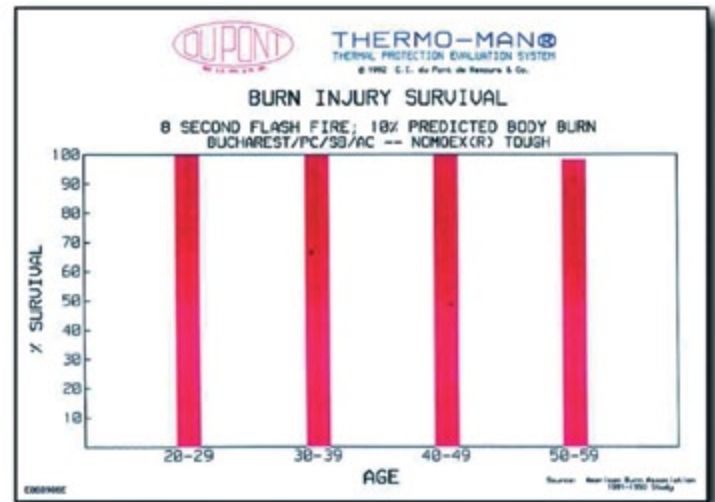

Burn injury survival





CAMOUFLAGE NET





3D CAMOUFLAGE NETS



CAMOUFLAGE NETS significantly reduce probability of detection by all the widely used sensors on the modern battlefield. They are intended for use as temporary or semi permanent concealment for various types of tactical equipment and field installations, disabling enemy observation. Camouflage nets are colored, textured and patterned to correspond with surrounding terrain. Nets are reversible to remain effective during all seasons (spring/summer, autumn/winter). They can be used for general purpose or tailored for specific assignment. Standard nets are rectangular shaped with basic measures in ratio 1:2 (6.0m x 12.0m and 3.0m x 6.0m). Upon request nets can be manufactured in any shape or size. Average weight of finished net is less than 300g/m². Nets can be easily assembled / disassembled by means of joining elements and set up over the object using net supporting accessory. Material is self- extinguishing, water - resistant, mold-resistant and applicable in temperature range from -30°C to +70°C. Colorimetric values and IR reflectance conform to natural environment. The mat surface has low gloss (max 2/85°). Trimmings provide a three dimensional texture.



Main battle tank M-84 camouflaged with three 6m x 12m nets



CAMOUFLAGE NET

SMICON MDP



visual

Camouflage Net reduces the possibility of detection by visual, electro-optical, IR, and radar devices depending on the net type selected. There are three types of camouflage nets depending upon the desired level of camouflage protection:
MD99-A / MD99-C

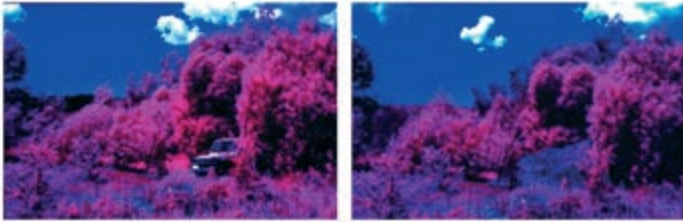

near IR

Type A - provides camouflage protection against reconnaissance in visual and near IR part of EM spectrum.

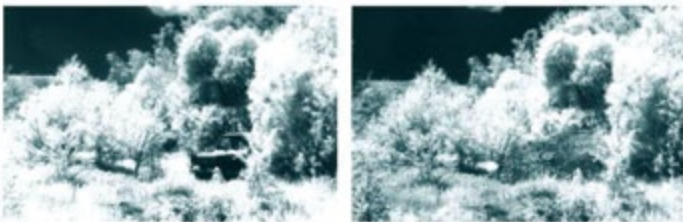

near IR black & white

Type C - provides camouflage protection against reconnaissance in visual, near IR, thermal IR (3 - 5 μm / 8 -14 μm) and radar part of EM spectrum.



Aerial IR color photography of vehicle camouflaged with MD99-net





2D CAMOUFLAGE NETS

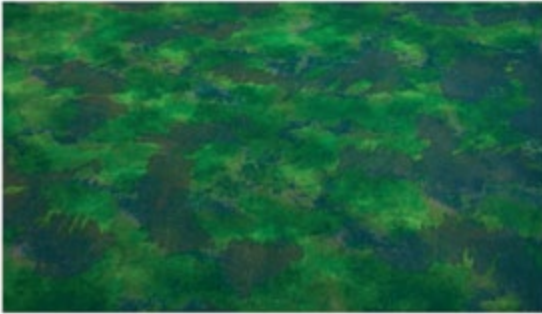

camouflage nets 2D woodland - type A



camouflage nets 2D desert - type A



camouflage nets 2D woodland - type C

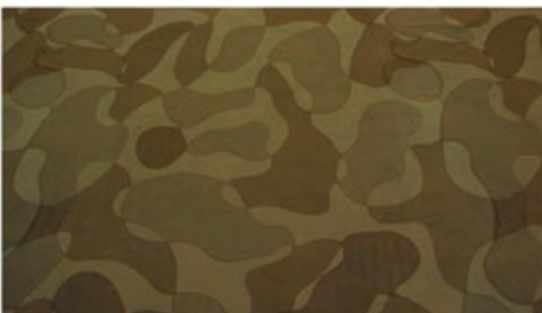

camouflage nets 2D desert - type C



UV electromagnetic spectrum



Intended for camouflaging of equipment and armament in areas partially or entirely covered with snow, in UV, visible, near IR, thermal IR and radar part of the electromagnetic spectrum.



CAMOUFLAGE NET

SMICON MDP



MD99-C nets smudge and distort thermal image of the concealed object thus producing the image similar to the natural environment in 3 - 5 μm and 8-14 μm regions of EM spectrum.

Thermal image - group of three aggregates

Left picture: Aggregates without camouflage

Right picture: Aggregates camouflaged with **MD99-C**

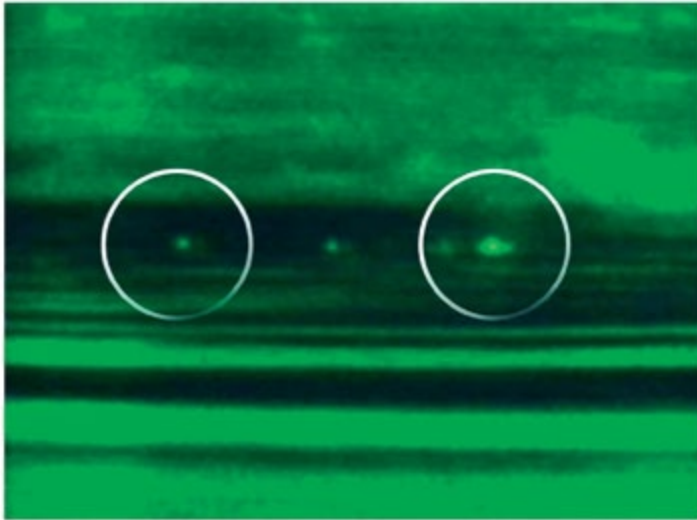

Thermal IR reflection of the object
befor camouflaging

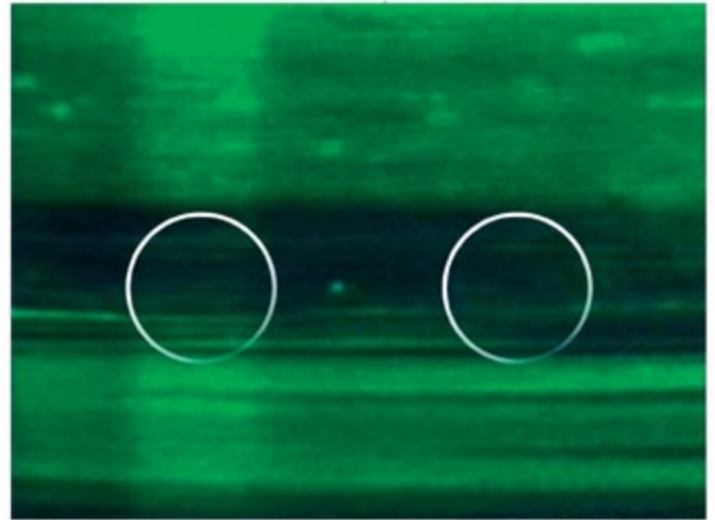

Thermal IR reflection of the object
after camouflaging

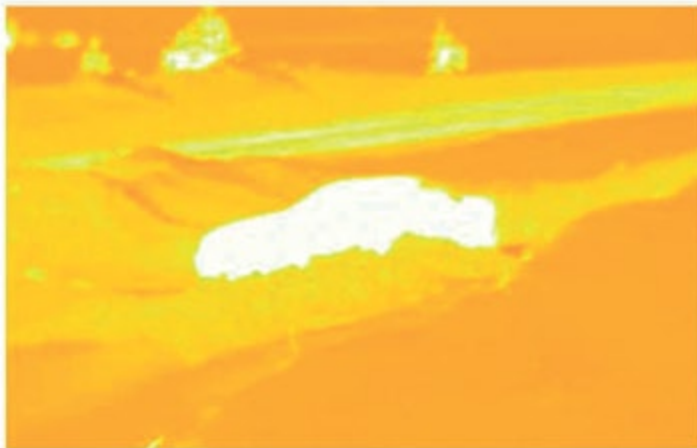

Thermal reflection of the object
befor camouflaging

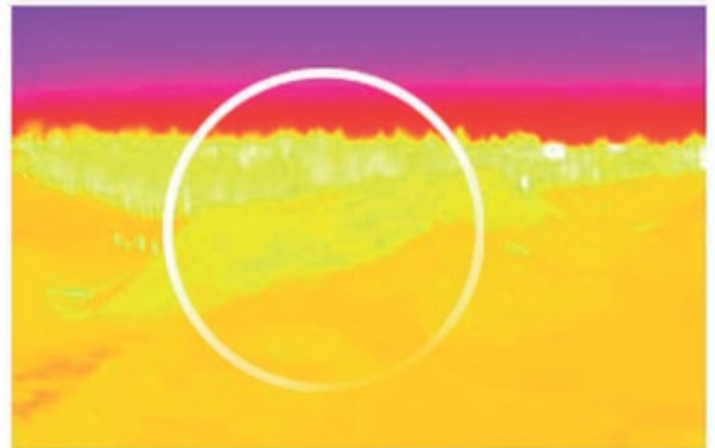

Thermal reflection of the object
after camouflaging



CAMOUFLAGE NET

SMICON MDP



MD99-C nets significantly reduce probability of detection by radar

Radar panoramic display - real image:

Left picture: truck without camouflage

Right picture: truck camouflaged with **MD99-C** nets

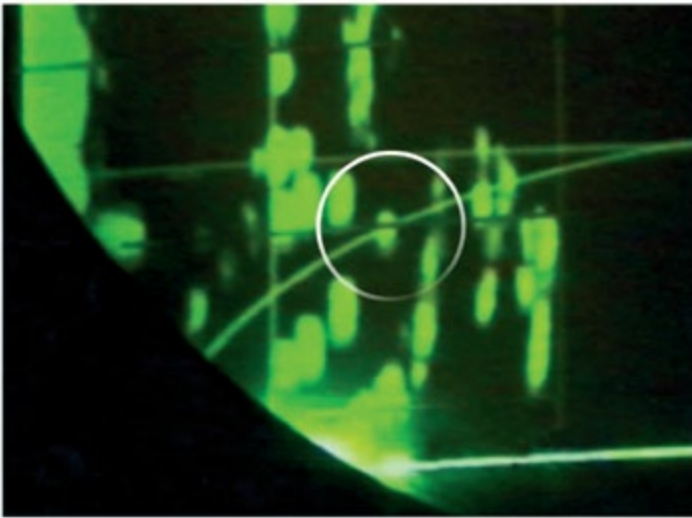

Without camouflage

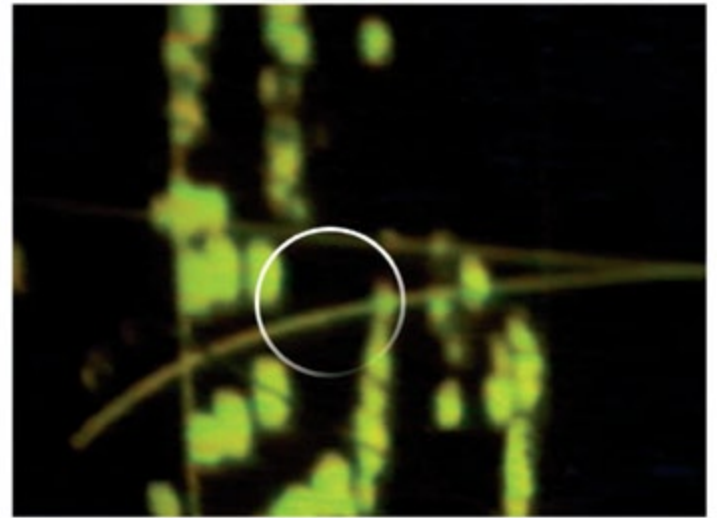

With camouflage

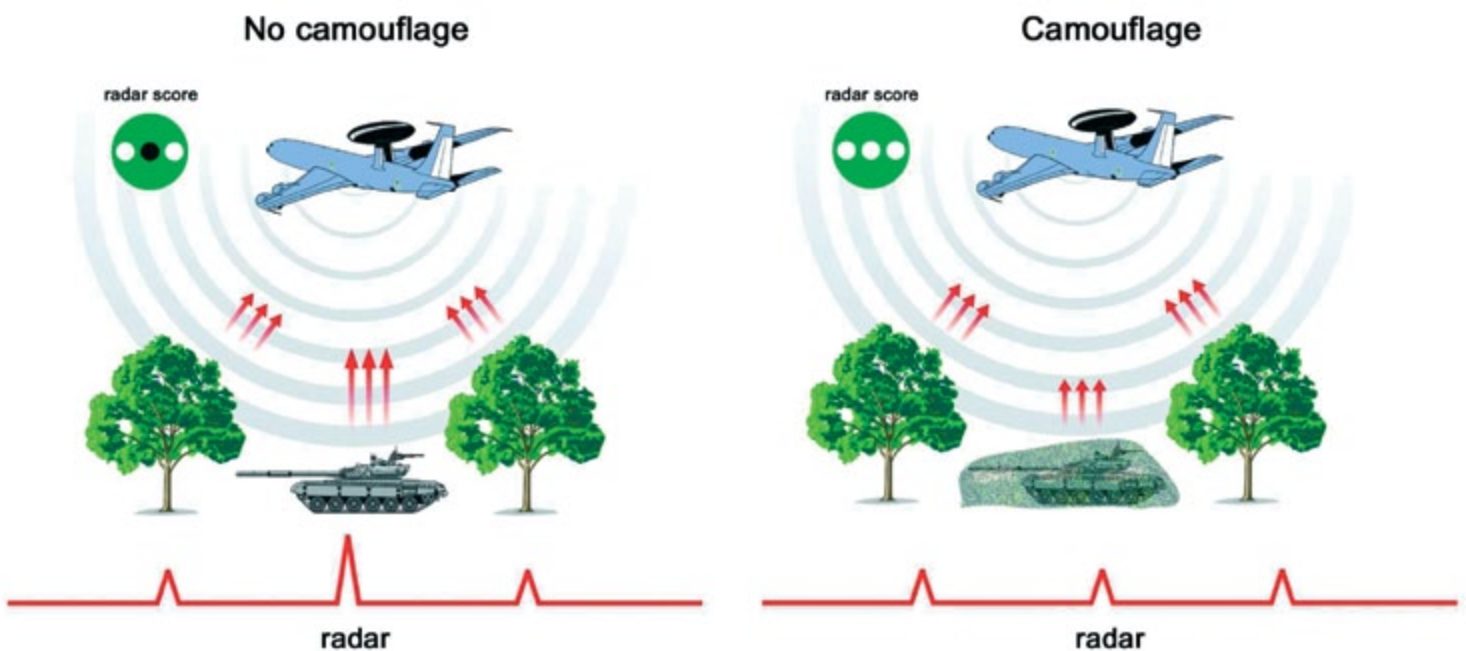

Schematic presentment of camouflage net effectiveness against airborne radar ("X" band - 3cm)





CAMOUFLAGE SUITS





SNIPER CAMOUFLAGE (GILLY SUIT)



It provides excellent camouflage of the whole body as well as personal armament. It is worn over battle uniform and allows high mobility in any field conditions. Sniper set consists of a poncho (pelerine), sleeves and gloves, stockings, helmet cover, a hood and scarf and camouflage stripes for personal armament.

It is designed in a way that it appears as a part of natural environment. Basic part of this camouflage suit is synthetic mesh which is upgraded with trimmings of characteristic colors that are made of an impregnated cloth or of synthetic mesh.

It is suitable against detection by naked eye and all types of observation and aiming devices (optical and optoelectronic devices) in visible and near IR part of the EM spectrum at close ranges (even closer than 10m). Sniper Camouflage is produced in one universal size that can be adjusted thanks to the special design of this suit.

The Sniper Camouflage Suit comes packed in suitable transport bag. Total mass of the camouflage suit, depending on the trimmings material (synthetic mesh / impregnated cloth) is 3.8 kg or 5.1 kg.

Product code: **31002599**





WINTER SNIPER CAMOUFLAGE (GILLY SUIT)



It provides excellent camouflage of the whole body as well as personal armament. It is worn over battle uniform and allows high mobility in any field conditions. Sniper set consists of a poncho (pelerine), sleeves and gloves, stockings, helmet cover, a hood and scarf and camouflage stripes for personal armament.

It is designed in a way that it appears as a part of natural environment. Basic part of this camouflage suit is synthetic mesh which is upgraded with trimmings of characteristic colors that are made of an impregnated cloth or of synthetic mesh.

It is suitable against detection by naked eye and all types of observation and aiming devices (optical and optoelectronic devices) in visible and UV part of the EM spectrum at close ranges (even closer than 10m). Sniper Camouflage is produced in one universal size that can be adjusted thanks to the special design of this suit.

The Sniper Camouflage Suit comes packed in suitable transport bag. Total mass of the camouflage suit, depending on the trimming material (synthetic mesh / impregnated cloth) is 3.8 kg or 5.1 kg.

Product code: **31002699**





WINTER CAMOUFLAGE SUIT M2000



The winter camouflage suit is intended for camouflaging all body parts of the soldier in snow surroundings, fully or partly covered with snow. It is worn over uniform and satisfies all criteria of functionality and camouflage ability while conducting combat missions in snow covered terrain.

The suit consists of: trousers, jacket (blouse), helmet cover, gloves, face camouflage and additional stripes for personal armament camouflage. It is made of white material with discrete, irregularly arranged dark spots (green or brown) to help merging into surroundings partially covered with snow, or where snow is melting or beginning to fall. In surroundings completely covered with snow the spots give out the impression of presence of natural elements such as: vegetation, stones etc.

Our Winter Camouflage Suits provide protection in UV, visible and near IR part of the EM spectrum against all types of observing and aiming devices (naked eye, photo-camera, optical, and optoelectronic devices). The reflection of the material in UV, visible and near IR part of spectrum corresponds to the reflection of the snow with "matte" surface and gloss less than $3/85^\circ$. Camouflage is successful even at small distances (<10m). The cut and size of the suit make it comfortable and enable wearing it over heavy winter clothes. It is produced in three different sizes.

Product code: 31002999



gloves



facial mask



helmet cover



stripes



bag





OVERALLS





TACTICAL ONE



Tactical One overalls allows full range of motion and is comfortable to wear under different temperature conditions. Its modern design makes it compatible with contemporary combat equipment and other elements of combat clothes.

There are two large chest pockets with flaps and Velcro loops for ID patches positioned above them. Front shoulder part has straps for radio devices or handcuffs placement. On the inner back side there is mesh lining for ventilation. There are also ventilation slits on the armpits and along the inner side of the sleeves. Pleated back with additional mesh for comfort and ventilation. Hidden elastic strings on the sleeves for height adjustment of the elbow-guards.

There are front slit pockets as well as cargo pockets on both hoses. Cargo pockets for placing various accessories (knife, mini flashlight or spare pistol magazine) are equipped with elastic stripes with dividers and are closing with flaps. They are additionally secured with plastic buckle and a strap that is also used for adjusting the height of knee-guards. There are two rear pockets with flaps as well as two rear cargo pockets which can be approached in sitting position. Shin pockets are equipped with elastic straps with dividers. Knee pockets for placing knee-guards. Reinforced seat area.

Sizes: M, L, XL, XXL

Product code: **31003399**





TANK OVERALL



Tank overalls are intended for use by combat vehicle crews. It is produced of special material **NOMEX**[®] that withstands high temperatures and it is fire retardant according to standard EN531 (A, B1, C1). The overall is equipped with a hidden drag handle on the back for quick pulling the user out of the vehicle when needed (in emergency situations). The overalls may come with protective cap for additional protection against heat.
Sizes: M, L, XL, XXL

Product code: **31003799**

NOMEX



PARACHUTE OVERALL



Parachute overalls is intended for use in extreme weather conditions where rapid temperature changes take place. It is produced of windproof, waterproof, thermo-regulating materials that are highly breathable. It provides comfort in temperature range from -50°C to +30°C.
Sizes: M, L, XL, XXL

Product code: **31005299**

NOMEX





PILOT OVERALL



The overalls are made of **Nomex**[®] material or of fabric that is a mixture of cotton and synthetic. Fastening is with zipper with two sliders. Reinforced shoulders. Sidelong chest pockets with zippers. Below the waist, on the left side, there is zippered opening for passage of the hose of anti-G suit. Waist size adjustment by means of flaps and Velcro system. Backing for attaching the navigation map is placed on the front side. Metal ring on the side of the left leg for attaching the surviving kit.

On the inside of thigh there is a pocket for knife, with flap and snap button. Zippered lower leg for opening size adjustment. Zippered pockets on the sides of hoses. Sleeves are ended with cuffs and have opening size adjustment by means of flaps and Velcro. They can be rolled up and fastened with button. Velcro loop mounting points for designations patches are placed on the front side.

Sizes: M, L, XL, XXL

Product code: 31004599

NOMEX



PILOT SET



Pilot sets are intended for various aircraft crews.

Pilot set consists of:

1. overall
2. insert
3. protective cap
4. jacket
5. boots
6. life-saving belt with automatic inflation system.

Overalls, insert and protective cap are produced of special material that withstands high temperatures and is fire retardant according to standard EN531 (A, B1, C1).

Sizes: M, L, XL, XXL

Product code: 31004899

SYMPATEX[®]
technology

NOMEX





TOP PATROL OVERALL



These Overalls are intended for equipping Military, Police units and Tactical Teams. Overalls are functional and comfortable and allow high degree of mobility. Full front opening with two zippers enable quick donning and doffing. Composing part of the overalls is removable thermo-insert made of synthetic fleece. Altogether, they protect from rain, wind and cold. Raised collar with Velcro girth adjustment keeps warmth in and wind out. Elastic band in the waist area for waist adjustment. Pleated back for better comfort and ease of movement.

The shoulder part is reinforced with double layers of fabric and synthetic filling. Also, there are double layers of fabric on the elbows, knees and buttocks area.

Legs and sleeve openings with elastic bands and cuffs with Velcro adjustment system. The sleeves can be made as removable. There are two large vertical zippered pockets on the front side, as well as few inner zippered pockets. Horizontal zippered pockets on the sides of hoses. Velcro mounting points for designations can be placed according to customer demands.

The overalls are made of materials of various colors and can be made to provide protection in visible and near IR part of EM spectrum.

Sizes: M, L, XL and XXL

Product code: **3 1 000399**

SKI OVERALL



Ski overall is intended for use in extremely low temperatures. It provides high level of protection in bad weather conditions.

Sizes: M, L, XL, XXL

Product code: **3 1 004199**

SYMPATEX[®]
technology







TACTICAL VEST



TACTICAL VEST

SMICON MDP



TOP UNIVERSAL
Product code: **31006099**

(measures in cm)

Size	Chest girth
M	88
L	92 - 96
XL	100 - 104
XXL	108 - 112

The basic material consists of synthetic mesh and impregnated cloth. The vest is equipped with functional holsters enabling various combinations. It has a built-in adjustment system and is produced in five sizes (M, L, XL and XXL). Tactical vest can be worn in combination with ballistic vest. Colors: various colors available as per customer request.



SHADOW SNIPER
Product code: **31006499**



TIGER
Product code: **31006899**

PUMA SNIPER
Product code: **31007299**





CLIMBING VEST



CLIMBING

Product code: **31007699**

(measures in cm)

Size	Chest girth
M	88
L	92 - 96
XL	100 - 104
XXL	108 - 112

CLIMBING VEST is intended for use by Special Operations Units, during missions that include transport and mounting of combat equipment in extreme situations (e.g. when climbing up and down). It is worn over the climbing belt and it is compatible with all kinds of belts.

Climbing vest is produced in several types depending on the type of combat equipment in use.



DESERT

Product code: **31008499**



POLICE

Product code: **31008099**



PANTHER

Product code: **31008899**







UNIFORMS





UNIFORMS

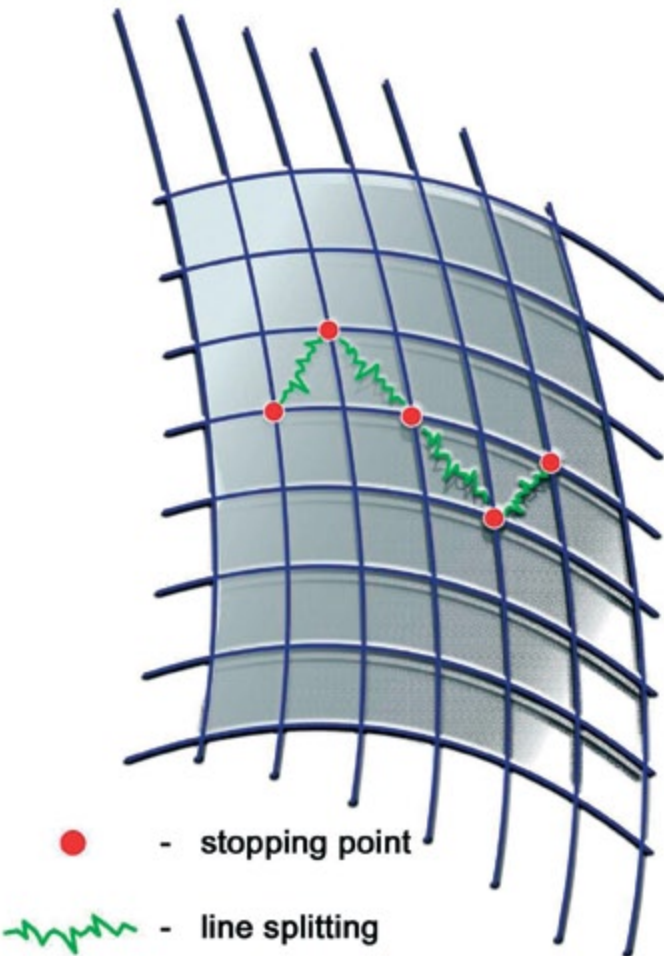

Uniforms are intended for equipping Military and Police units and Tactical Teams. Uniforms are produced in several models, depending on the customer requirements. They are functional and comfortable and they provide high degree of mobility.

Also, we can provide thermo-inserts with various protection levels against cold weather. Our camouflage uniforms are made of materials of various colors and can be made to provide protection in visible and near IR part of EM spectrum.

Available sizes: M, L, XL and XXL.

Table of measures

(measures in cm)

Size	Chest girth	Waist girth	Inside leg length
M	88	80	78
L	92 - 96	84 - 88	79 - 80
XL	100 - 104	92 - 96	81 - 82
XXL	108 - 112	102 - 106	83 - 84

Remark:

Inside leg length is the distance between the crotch and the soles of the feet.

THE OUTLAST OPTION

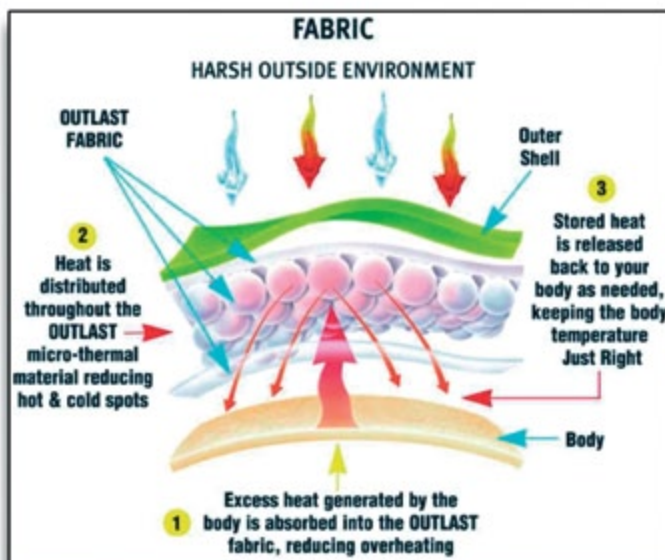

Company **SMICON**, a licensed partner of **OUTLAST®**, offers to the customers the option of including **OUTLAST®** lining in any of its uniforms. Uniforms made with **OUTLAST®**, a thermo-regulating fabric originally designed for use in space, are more comfortable to wear as the material will absorb, store and release excess body heat. Therefore the user experiences less sweat and less chill, for temperature changes are balanced. Outlast works at the molecular level to provide greater comfort in all weather conditions.





TACTICAL ONE OVERALLS



Tactical One overalls allows full range of motion and is comfortable to wear under different temperature conditions. Its modern design makes it compatible with contemporary combat equipment and other elements of combat clothes.

There are two large chest pockets with flaps and Velcro loops for ID patches positioned above them. Front shoulder part has straps for radio devices or handcuffs placement. On the inner back side there is mesh lining for ventilation. There are also ventilation slits on the armpits and along the inner side of the sleeves. Pleated back with additional mesh for comfort and ventilation. Hidden elastic strings on the sleeves for height adjustment of the elbow-guards.

There are front slit pockets as well as cargo pockets on both hoses. Cargo pockets for placing various accessories (knife, mini flashlight or spare pistol magazine) are equipped with elastic stripes with dividers and are closing with flaps. They are additionally secured with plastic buckle and a strap that is also used for adjusting the height of knee-guards. There are two rear pockets with flaps as well as two rear cargo pockets which can be approached in sitting position. Shin pockets are equipped with elastic straps with dividers. Knee pockets for placing knee-guards. Reinforced seat area.

Sizes: M, L, XL, XXL

Product code: 31003399





TACTICAL ONE - BLOUSE



Ergonomic design of the blouse Tactical One makes it comfortable and allows full range of motion. It is compatible with contemporary combat equipment and other elements of combat clothes. There are two large chest pockets with Velcro loop mounting points for ID patches positioned above them. Front shoulder part has straps for radio devices or handcuffs placement. On the inner back side there is mesh lining for ventilation. There are also ventilation slits on the armpits and along the inner side of the sleeves. Pleated back with additional mesh for comfort and ventilation. Hidden elastic string on the sleeves for height adjustment of the elbow-guards.

Sizes: M, L, XL, XXL

Product code: **31009699**

TACTICAL ONE - TROUSERS



Tactical One Trousers are comfortable and provide high degree of mobility.

There are front slit pockets (on thighs) as well as front cargo pockets on both hoses equipped with elastic stripes with dividers. Cargo pockets have additional closure with plastic buckles and straps that can also be used for adjusting the height of knee-guards. There are two rear pockets with flaps as well as two rear cargo pockets which can be approached in sitting position. Shin pockets are equipped with segmented elastic tape. Knee pockets for placing knee-guards. Reinforced seat. Wide reinforced belt loops accommodate tactical belts.

Sizes: M, L, XL, XXL

Product code: **31010099**





FORMAL UNIFORM



MALE UNIFORM

Product code: 31010499



FEMALE UNIFORM

Product code: 31010899

Coat is slightly waisted and has lapels. It is made of mixture of wool and polyester. Fastening is with decorative buttons. Decorative cords and braids on the front. Female model is tailored according to feminine figure.

Sizes: M, L, XL, XXL.

Trousers are of a flat style with waistband and belt loops. Fastening is with zipper and button. There are angle-cut hand pockets. Button through hem pocket on the back side. Female model is tailored to fit feminine figure.

Sizes: M, L, XL, XXL.





UNIFORM OF MUNICIPAL POLICE



Jacket

The jacket is made of 2-ply breathable **Sympatex®** fabric. Fastening is with zipper and double protective flap. Beneath the flap there is a vertical zippered pocket. Removable collar is made of fur. There are epaulettes on shoulders. Backings for attaching user ID marks are placed on the front part of the jacket as well as on the sleeves. There are sidelong hand pockets with flaps and hidden snap buttons. Sleeves are ended with cuffs. Sleeve opening size adjusting by means of flaps and Velcro. Zippered slits on the sides of jacket. Reflective tapes on the front shoulder part. **3M®** reflective thermo-foil inscription on the back.

Sizes: M, L, XL, XXL

Product code: **31011299**



Shirt

This shirt is of a flat style with lapel collar and is made of fabric that is mixture of synthetic and cotton. Fastening is with buttons. Removable epaulettes on shoulders. Chest pockets with flaps with buttons. Sleeves are ended with cuffs that are fastening with buttons. Pleated back yoke for better comfort. Backings for attaching designations are placed on the chest part and on the sleeves.

Sizes: M, L, XL, XXL

Product code: **31011699**

Trousers

Trousers are made of fabric that is mixture of cotton and synthetic. Fastening is by means of zipper and button. Waistband has belt loops. Legs are of flat style. Angle-cut hand pockets. Pocket with flap on the rear side of pants.

Sizes: M, L, XL, XXL

Product code: **31012099**





COMBAT JACKET



This jacket is of a short style and is made of synthetic fabric with protective coating. There are two hand pockets with flaps with Velcro tapes. Gusseted armpits for better comfort and ease of motion.

The jacket is reversible and has thermo-insulation made of material THINSULATE. There are cuffs on the bottom part of the jacket and on the sleeve endings. Fastening is by means of zipper with double slider with protective flap underneath. Inner side of the jacket is of orange color with 3M® grey reflective tapes sewn on it for easier spotting of the user.

Sizes: M, L, XL, XXL

Product code: **31012499**

PROBE JACKET



This jacket is of a long style made of synthetic fabric with protective coating. It has raised collar and removable hood that is face opening and height adjustable. Fastening is by means of zipper with two sliders and two protective flaps with snap buttons. There are two backings for attaching the radio device microphone and cables in the shoulder area. Two double pockets are placed in the chest area, where upper is with flap and lower is with side opening. There on the left pocket is a loop made of fabric for attaching carabineers. Two sidelong hem pockets are placed on the waist. There are Velcro loop mounting points for ID patches on the front side. Sleeves are ended with cuffs and have opening size regulation system by means of flaps and Velcro tapes. Ventilation slits in the armpits. There on the back is the plastron closed by means of Velcro tapes with cloth that carries ID marks placed underneath. Lining is made of synthetic mesh. Under jacket is made of breathable SYMPATEX® knitted fabric WINDMASTER and has two hand pockets with zippers. It is attached to the jacket by means of zippers.

Sizes: M, L, XL, XXL

Product code: **31012899**





TACTICAL SHIRT



Body shaped shirt with raised zippered collar. Raglan sleeves for full range of motion. Basic material is thermo-regulating material like **OUTLAST®**. Upper parts of the sleeves are reinforced with cotton/polyester fabric. Different colors and patterns are available. Two sidelong pockets with flaps with hidden closure are placed on the sleeves.

The shirt with long sleeves has sleeve openings Velcro adjustment system. Additional layer of fabric on elbows.

MOLLE system for attaching the holsters for communication devices is placed on the chest.

Options:

- Basic material is 100% cotton.
- Velcro loop mounting points for ID patches on sleeves.

Sizes: M, L, XL, XXL



Tactical shirt with short sleeve

Product code: **31016299**

Tactical shirt with long sleeve

Product code: **31013299**

PROBE T-SHIRT



The shirt is constructed of pique knitted fabric. It has flat knitted ribbed collar with two buttons. There is a backing on the left shoulder for attaching the microphone with cable. Designations made of reflective **3M®** foil is placed on the front.

Options:

- Reflective inscription on the back
- Velcro loop mounting points for ID patches on the front side

Sizes: M, L, XL, XXL

Product code: **31013699**





SKI SUIT



It is made of three-ply breathable **SYMPATEX®** fabric and provides protection from rain, wind and cold.

Ski jacket

The jacket is of a flat style with raglan sleeves. Raised collar keeps the wind out and warmth in. Embedded **3M®** reflective tapes on the front part of the jacket enable easy spotting of the user. Full zippered front opening with double protective flap. Two zippered chest pockets with flaps. In the right pocket there is a backing for hidden carrying of designations. All outer pockets are closed with water-repellent zipper. Backings for attaching ID marks on the front side. Zippered ventilation slits on the armpits. Drawstring adjustable waist and bottom hem. Zippered openings on the sides of the jacket for easy access to the pockets on pants. Removable hood. Under jacket is made of breathable **SYMPATEX®** knitted fabric of type "Windmaster".

Options:

- Inscriptions on shoulders and back made of **3M®** reflective foil
- Embroidered marks on the under jacket.

Sizes: M, L, XL, XXL

Product code: **31014099**

Ski trousers

Trousers are of a flat style with elastic suspenders. Lining is made of thermo-insulating material **THINSULATE**. Fastening is by means of zipper and snap button. Pockets are with water-repellent zippers. Inner side of legs is reinforced with synthetic fabric with protective coating. Reinforced knees. Zippers on bottom legs for easy donning and straps with Velcro tapes for additional adjusting of leg opening size. Waistband is with belt loops. Belt made of double synthetic tape is fastening with double retention plastic buckle.

Sizes: M, L, XL, XXL

Product code: **31014499**





SWEATER TOP PATROL K



It is a woven sweater with zippered turtle neck that in combination with other clothing provides protection against low temperatures.

Shoulders and elbows are reinforced with a layer of fabric.

Colors: camouflage, green, black, dark blue.

Sizes: M, L, XL, XXL

Product code: 31014899

SWEATER TOP PATROL O



It is a woven sweater with round neckline that in combination with other clothing provides protection against low temperatures.

The shoulder and elbows are reinforced with a layer of fabric.

Colors: camouflage, green, black, dark blue.

Sizes: M, L, XL, XXL

Product code: 31015299





BOOTS AND SHOES



BOOTS AND SHOES

SMICON MDP



Boots and shoes produced by **SMICON** are made of natural full grain leather, and they are highly resistant to water penetration. They are made in several different models (summer, winter or universal), and in different sizes according to the French measurement system, in range from 39 to 46. Boots and shoes have inner lining made with multi-layer materials, such as **SYMPATEX®** and **OUTLAST®**. High density rubber sole is designed to be flexible, highly resistant to abrasion and cracking, and at the same time to be as light as possible. The upper part of boots and shoes is either glued, or both stitched and glued to the sole, depending on the model.

Comparative shoe size table

EUR	39	40	41	42	43	44	45	46
US	6.5	7	8	8.5	9.5	10	11	11.5
UK	6	6.5	7.5	8	9	9.5	10.5	11
cm	26	26.5	27.5	28	28.5	29.5	30	30.5

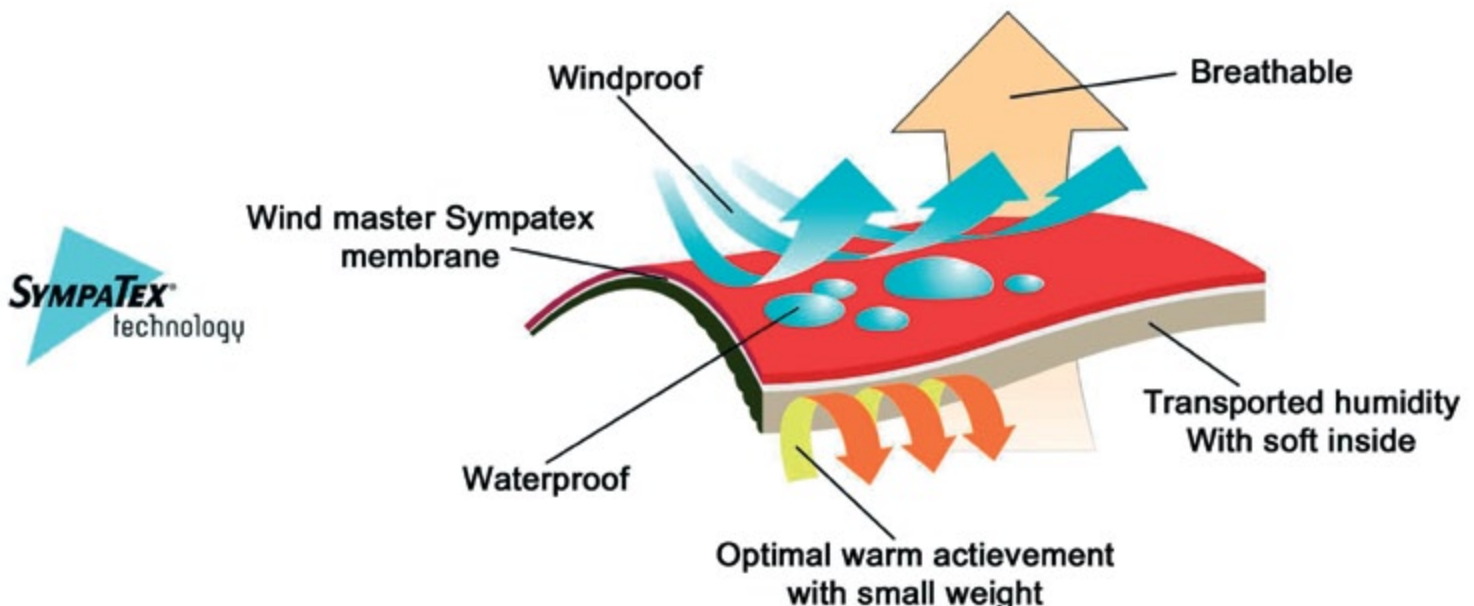

SYMPATEX® membrane is highly breathable, 100% waterproof and 100% windproof high technology membrane that is used in production of clothes, footwear, gloves and caps. **SYMPATEX®** materials provide effective protection along with great comfort.

OUTLAST® is a high tech lining fabric used in high quality footwear for temperature regulation. **OUTLAST®** technology regulates body temperature by absorbing and releasing heat, creating a unique microclimate that keeps feet at a comfortable temperature.

-  100% windproof
-  100% waterproof
-  highly breathable

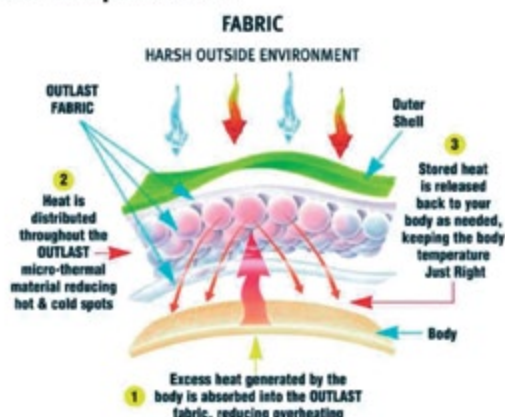



TOP PATROL BOOTS

This is terrain footwear made of cowhide leather, resistant to bending, worked to be water-repellent and to keep the shine, softness and cracking resistance. Inner lining is made of leather or it is made with **OUTLAST®** lining or with **SYMPATEX®** membrane.

The sole is made of rubber or combination of rubber and polyurethane, and it is either glued or both stitched and glued to the upper part of the boots.

Sizes: from 39 to 46

Product code: **31600099**



PROFESSIONAL BOOTS

This is terrain footwear made of cowhide leather, resistant to bending, worked to be water-repellent and to keep the shine, softness and cracking resistance. Inner lining is made of leather or it is made with **OUTLAST®** lining or with **SYMPATEX®** membrane.

The sole is made of rubber or combination of rubber and polyurethane, and it is either glued or both stitched and glued to the upper part of the boots.

Sizes: from 39 to 46

Product code: **31601099**





QUEST SHOES

This is terrain footwear made of cowhide leather, resistant to bending, worked to be water-repellent and to keep the shine, softness and cracking resistance.

Sole is made of rubber or combination of rubber and polyurethane and is either glued or both stitched and glued to the upper part.

Sizes: from 39 to 46

Product code: 31602099



TACTIC SHOES

This is terrain footwear made of cowhide leather, resistant to bending, worked to be water-repellent and to keep the shine, softness and cracking resistance. Inner lining is made of leather or it is made with **OUTLAST®** lining or with **SYMPATEX®** membrane.

The sole is made of rubber or combination of rubber and polyurethane, and it is either glued or both stitched and glued to the upper part of the shoes.

Sizes: from 39 to 46

Product code: 31603099





SQUAD 1 BOOTS

Terrain footwear made of cowhide leather, resistant to bending, worked to be water repellent and to keep the shine, softness and cracking resistance. Leather lining.

The sole is made of rubber or combination of rubber and polyurethane and it is glued to the upper part of the shoes.

Sizes: from 39 to 46

Product code: 31604099



SQUAD 2 BOOTS

Terrain footwear made of cowhide leather, resistant to bending, worked to be water repellent and to keep the shine, softness and cracking resistance. Antibacteric synthetic lining.

The sole is made of rubber or combination of rubber and polyurethane and it is glued to the upper part of the shoes.

Sizes: from 39 to 46

Product code: 31605099





OFFICER BOOTS



SQUAD SHOES

Terrain footwear made of cowhide leather, resistant to bending, worked to be water repellent and to keep the shine, softness and cracking resistance. Antibacteric synthetic lining.

The sole is made of rubber or combination of rubber and polyurethane and it is glued to the upper part of the shoes.

Sizes: from 39 to 46

Product code: 31606099



OFFICER BOOTS

Both outside and inside of these boots are made of high quality calf leather.

Sole is made of leather and it is both glued and stitched to the upper part.

Sizes: from 39 to 46

Product code: 31607099





TEMPO SHOES

This is terrain footwear made of cowhide leather, resistant to bending, worked to be water repellent and to keep the shine, softness and cracking resistance.

The sole is made of rubber or combination of rubber and polyurethane, and it is either glued or both stitched and glued to the upper part of the shoes.

Sizes: from 39 to 46

Product code: **31609099**



GUARD SHOES

This is urban footwear made of cowhide leather resistant to bending, worked to be water repellent and to keep the shine, softness and cracking resistance.

The sole is made of rubber, and it is both stitched and glued to the upper part.

Sizes: from 39 to 46

Product code: **31608099**





OFFICER SHOES

These shoes are made of high quality calf leather both on the outside and on the inside. The sole is made of leather and it is both stitched and glued to the upper part.
Sizes: from 39 to 46

Product code: 31610099



FEMALE OFFICER SHOES

These shoes are made of high quality calf leather both on the outside and on the inside. The sole is made of leather and it is both stitched and glued to the upper part.
Sizes: from 36 to 46

Product code: 31611099





BACKPACKS AND BAGS





ATU BACKPACK



Backpack is constructed of durable synthetic fabric with protective coating. It is intended for carrying combat equipment. Its design provides even weight distribution.

Total volume is around 120 l. Side cargo pouches are detachable and can be used independently. They have volume of 7.5l each. Volume of the main compartment is 85l and it has detachable cover with volume of 5l. On the main compartment there is a pocket for placing rifle. Cover, front and side pouches are closing by means of zippers. They also have synthetic draw-strings for size adjustment. Inside the front pouch there is additional zippered opening for easy access to the main compartment.

On the lower part of the main compartment there is a separate space that is closing with zipper and also can be accessed from the outside.

Pouches and the main compartment are additionally secured with synthetic compression straps.

On the front side of the backpack there is a heavy duty carry/drag handle. Adjustable padded shoulder straps and chest straps. Adjustable padded waist belt with triple retention plastic buckle. Stiffened and padded back panel. Upon request, backpack can be equipped with waterproof covering.

Color: camouflage, green, blue and black

Product code: **31900199**





MODULAR BACKPACKS



Modular backpacks are produced using high-quality, synthetic, abrasion resistant material. Its design provides even weight distribution. Our **Modular backpack** consists of two parts: **Transport backpack** and **combat backpack** where each of them can be used independently. Both packs have adjustable padded shoulder straps and drag/carry handles, as well as adjustable webbing straps for carrying sleeping bag, sleeping pad or tent.

The **transport backpack** consists of the main chamber with cover and two side cargo pockets with flaps. There is enough space left between those pockets and the backpack sides for placing the rifle. On the rear outer side of the cover there is a zippered pocket. There are also adjustable chest straps and waist belt with plastic buckles.

Dimensions: 750mm x 600mm x 220mm

Volume: 60 L (with pockets)

Combat backpacks consists of main chamber with zippered cover and two detachable holsters with metal buckles. It also has adjustable chest straps with plastic buckle.

Volume is approximately 25 liters.

Color: camouflage, green, blue and black

Product code: 31900099





MEDICAL BACKPACKS



Product code: 31900299

We also offer a Medical Backpack intended for medical staff. We offer these backpacks in various models for Rescue Teams, Military and Police. These backpacks provide quick-view and easy access to medical supplies, as well as comfortable carrying. Medical backpacks are constructed to secure the content against water penetration and mechanical impacts. Our standard medical backpacks are produced in three models:

- First aid bag,
- Medical bag and
- Doctors bag.



OFFICERS BAGS



Officers bags are used for keeping necessary equipment and kits. They are made of top-quality materials.

Product code: 31900399





BELTS AND HOLSTERS





TACTICAL BELT

Tactical Belt is intended for Special Units. The belt is produced of high durability synthetic cloth, padded with foam and bordered with synthetic brim tape. Belt is length adjustable and is fastening with double retention plastic buckle. Various holsters can be attached to the belt, for instance:

- magazine holster
- handcuffs holster
- thigh rig pistol holster
- Motorola holster.

The holsters are produced of highly durable synthetic cloth and have openings for pulling the belt through. The Motorola holster is intended for type GP-300 and equipped with a synthetic lace for securing the device. The handcuffs and magazine holsters have covers with snap buttons and Velcro. Holes on the bottom provide water draining.

The design of Thigh Rig Pistol Holster combines secure weapon carrying with quick drawing. The weapon is secured with plastic or webbing tapes. The pistol holster is fixed to the leg thigh harness that is mounted to the belt via strap that is length adjustable. Holster with leg thigh harness is made of highly durable synthetic cloth and padded with foam. Consisting part of the harness are synthetic and elastic straps for wrapping around the thigh for holster retention, thus enabling quick weapon drawing and re-holstering. Holster has drawing force regulation system.

Colors: Black

Model: CZ99; Magnum 357; Glock 17/19; 7.62; HS2000; Sig Sauer 225



No.	Composing parts of the belt	Product code
1.	magazine holster	31900499
2.	handcuff holster	31900599
3.	thigh rig pistol holster	31900699
4.	radio device holster	31900799
5.	belt	31900899





LEATHER SET

This set is intended for use by Police members when they are performing their regular patrol duty. It is suitable for side carrying of the weapon and for attaching other necessary equipment. The set is produced of high quality leather. Fastening is with metal buckle.

Pistol holster with carrier is made of high quality leather and is reinforced with plastic. The holster is with leather lining. The plastic reinforcement provides that the holster is rigid thus enabling quick weapon drawing and re-holstering. There is a leather strap for securing the weapon.

The set consists of: belt, pistol holster, magazine holster, handcuffs holster, holster for flashlight, radio device holster, baton loop.

Other elements can be added to the Leather set according to customer demands.

Color: black or white

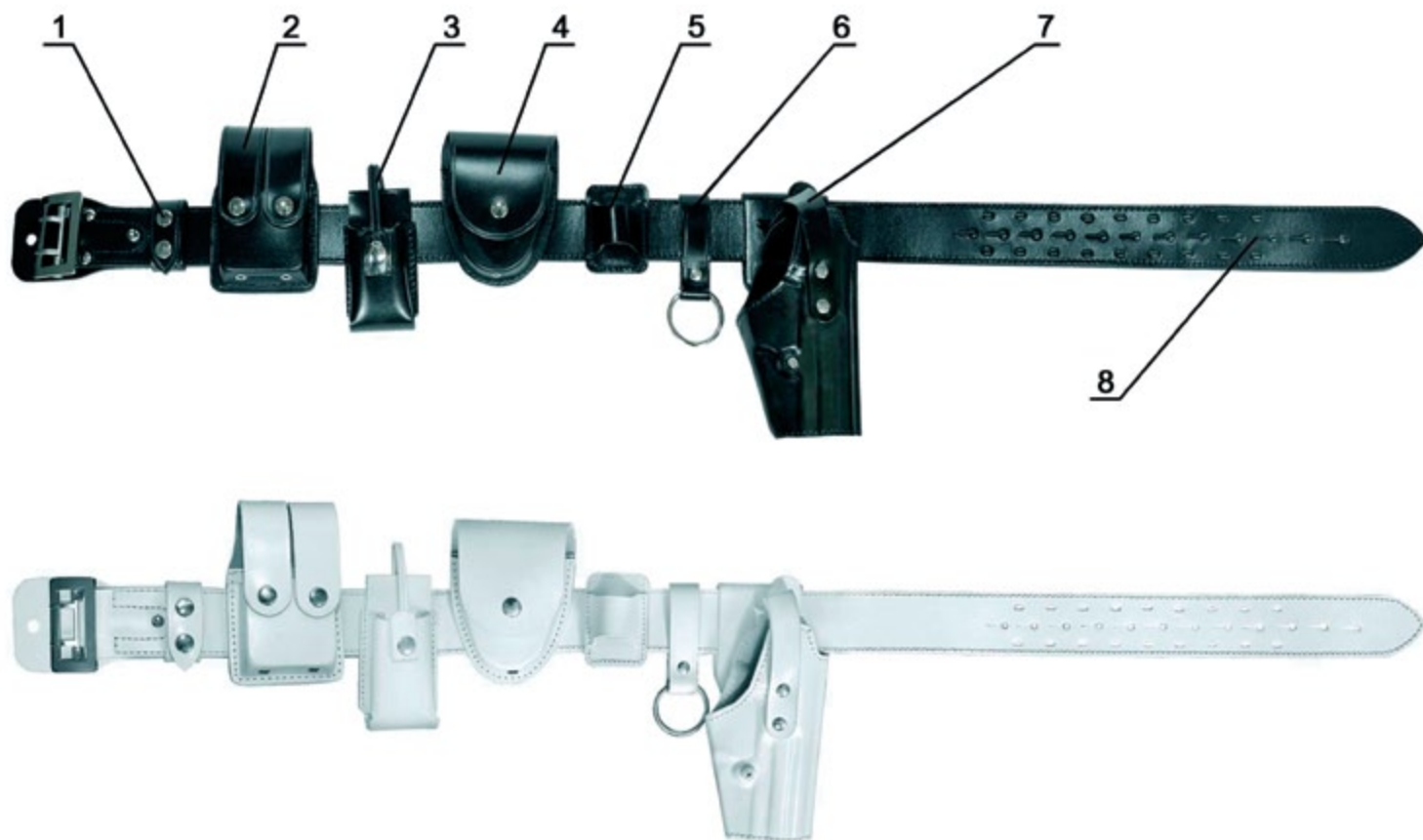

No.	Composing parts of the belt	Product code
1.	Belt loop	31900999
2.	Double magazine holster	31901099
3.	Radio device holster	31901199
4.	Handcuff holster	31901299
5.	Pistol lamp holster	31901399
6.	Baton carrier	31901499
7.	Pistol holster	31901599
8.	Belt	31901699





ATU BELT WITH HOLSTERS

This belt is produced of nylon that is reinforced with polymer material on the inner side to provide higher durability and comfort. Length adjustment with Velcro tape and fastening with double retention plastic buckle.

Colors: Black

Model: CZ99; Magnum 357; Glock 17/19; 7.62; HS2000; Sig Sauer 225

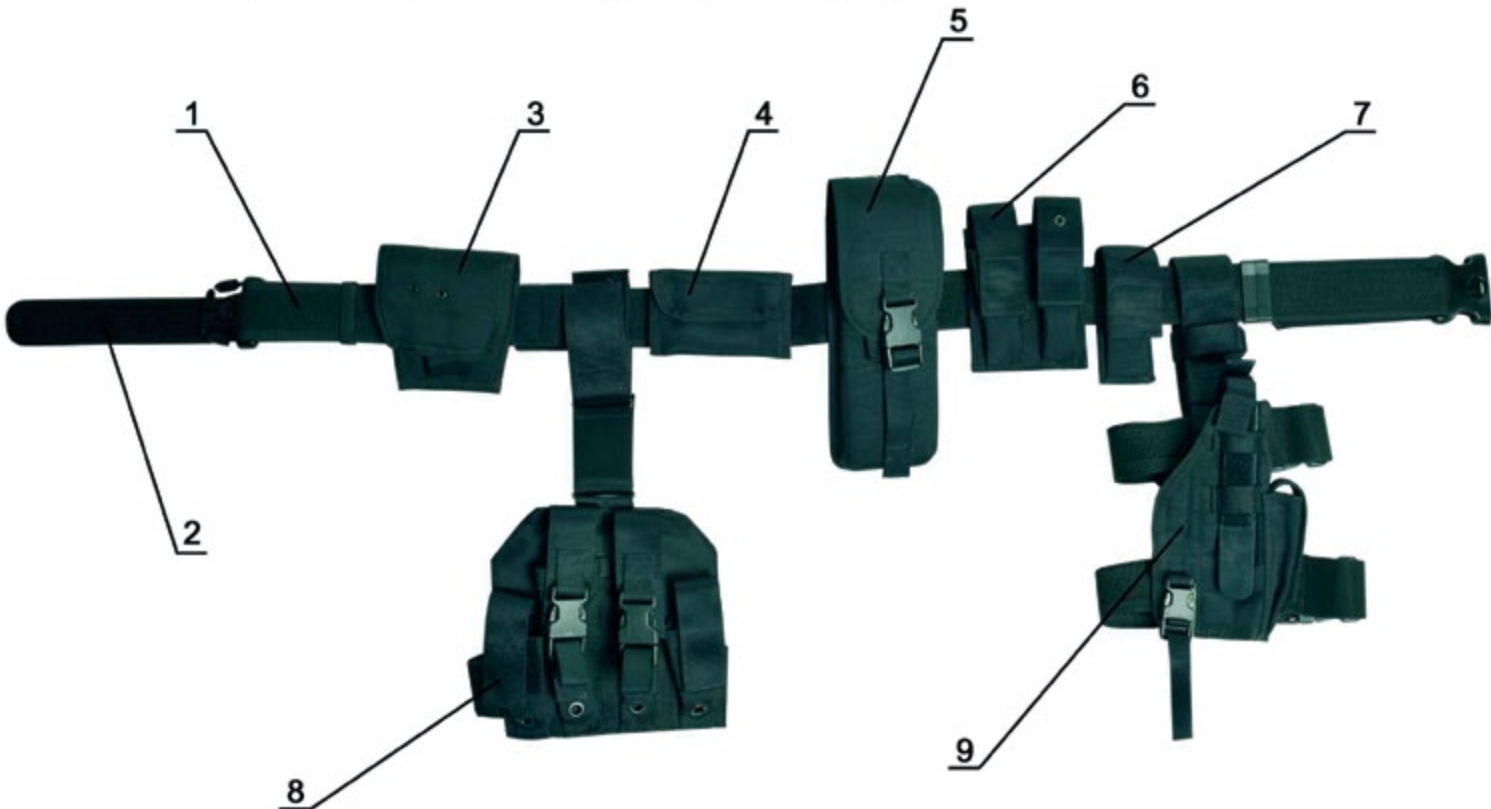

No.	Composing parts of the belt	Product code
1.	Belt	31901799
2.	Under belt	31901899
3.	Double handcuff holster	31901999
4.	Gloves holster	31902099
5.	Radio device holster	31902199
6.	Double magazine holster	31902299
7.	Pistol lamp holster	31902399
8.	Four magazines holster	31902499
9.	Pistol holster	31902599





REFLECTIVE BELT WITH HOLSTERS

It is made of waterproof foam with synthetic lining. It has four plastic belt loops for length adjustment. Fastening is with triple retention plastic buckle. 3M® reflective tapes for easy spotting of the user.

All the holsters have belt loops for attaching them onto the belt.

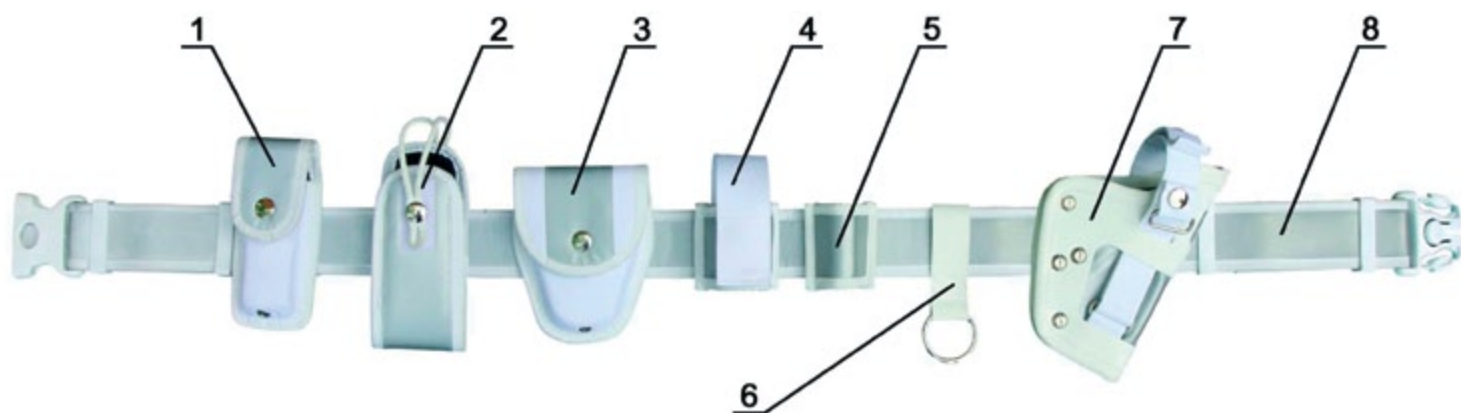

No.	Composing parts of the belt	Product code
1.	Magazine pouch	31902699
2.	Holster for radio device	31902799
3.	Handcuffs holster	31902899
4.	Holster for flashlight	31902999
5.	Hand held STOP sign carrier	31903099
6.	Baton carrier	31903199
7.	Pistol holster	31903299
8.	Belt	31903399





HOLSTERS

Holsters and belts are produced of high quality leather or synthetic materials to satisfy user demands for high durability and comfort. We produce pistol holsters for all types and calibers of pistols and revolvers. Belts enable numerous combining of various holsters.



Belt Pistol Holsters
Product code: 31907099



Belt Pistol Holsters
Product code: 31906999



Pistol Holsters For Side Carryng
Product code: 31907199





HOLSTERS



Pistol Holster For
Hidden Carryng
Product code: **3 1 9 0 4 3 9 9**



Pistol Holster For
Hidden Carryng
Product code: **3 1 9 0 4 5 9 9**



Leather Belt Holster
With Carrier
Product code: **3 1 9 0 4 7 9 9**



Lower Shin Holster
Product code: **3 1 9 0 4 9 9 9**



Lower Shin Holster
Product code: **3 1 9 0 5 0 9 9**



Fast Release Pistol Holster
Product code: **3 1 9 0 5 3 9 9**



Pistol Belt Holsters
Product code: **3 1 9 0 5 4 9 9**



Axillary Holster
Product code: **3 1 9 0 5 5 9 9**





HOLSTERS



Spare Bullets Holster 12/70
31906099



Fire Bomb Holster
31906199



Double Magazine
Holster
31906299



Smoke Bomb
Holster
31906399



Double Magazine
Holster For AK
31906499



Protective Mask Holster
31906599



HKMP5 Magazine Holster
31906699



Empty Frame Holster
31906799



Pistol Magazine Holster
31906899





About us	1
Certificate	2
Helmets	3
Ballistic plates	7
Ballistic vests	11
Deming armor	31
Ballistic shields	37
Anti-riot equipment	45
Protective suits	51
Camouflage net	59
Camouflage suits	65
Overalls	69
Tactical vest	75
Uniforms	79
Boots and hoes	89
Backpacks and bags	97
Belts and holsters	101



SMiCON

performance. regardless.

**OFFICE UAE / DUBAI - Jumeirah Lake Towers
POB 71742 - Dubai - United Arab Emirates**

e-mail: info@smicon.com - web: www.smicon.com